

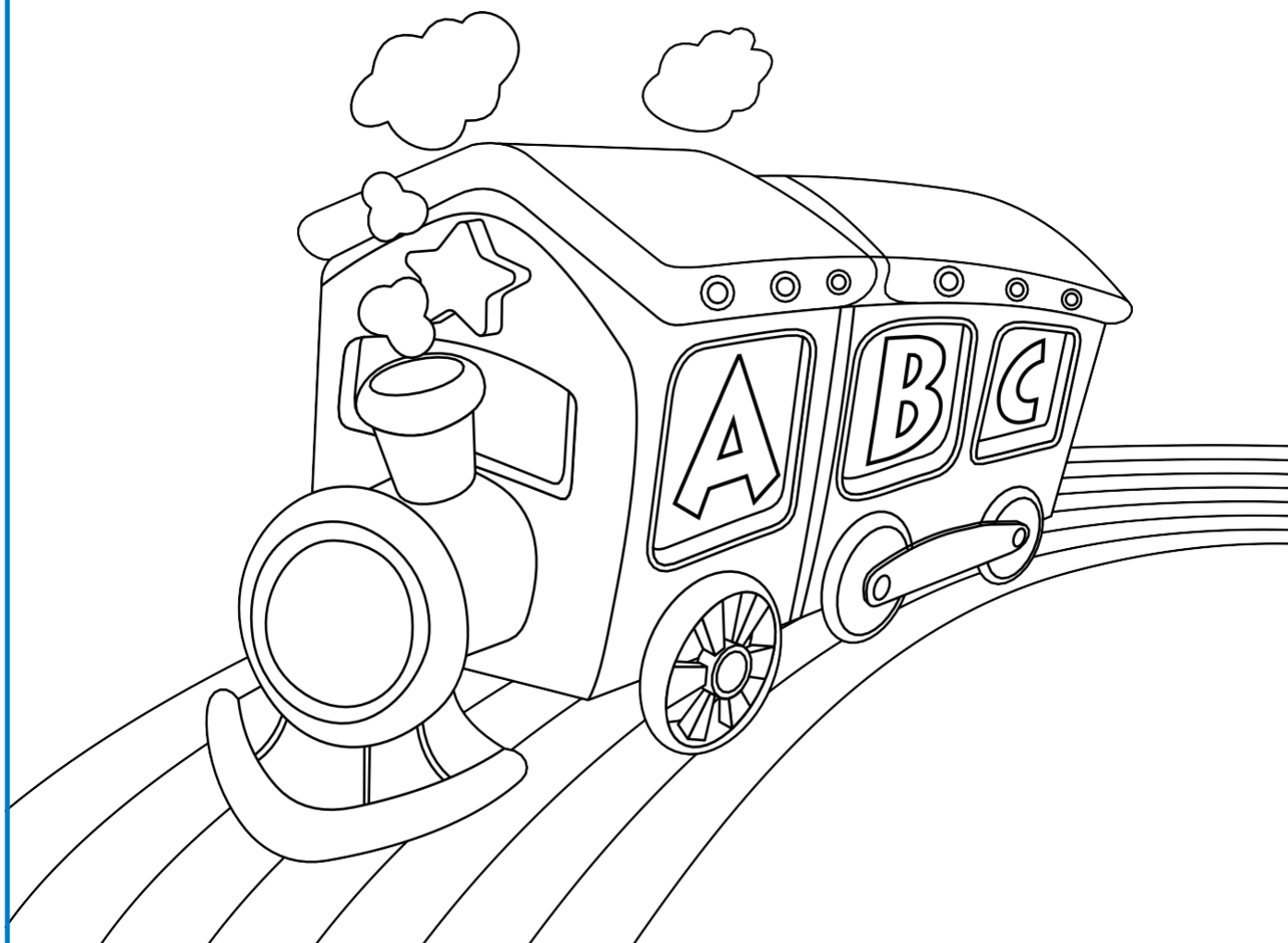

MUNICÍPIO DA ESTÂNCIA BALNEÁRIA DE PRAIA GRANDE

Estado de São Paulo
SEDUC - Secretaria de Educação

MATERIAL DE APOIO



Escola Municipal: _____

Nome: _____

Ano: _____ Sala: _____

Professor (a): _____

INFANTIL II
1º SEMESTRE

SECRETARIA DE
EDUCAÇÃO



Olá,

Você está recebendo o Material de Apoio elaborado pelo grupo de Assistentes Técnicos Pedagógicos e Equipe da Secretaria de Educação.

O Material de Apoio vai ser uma ajuda extra para que você possa compreender melhor os conteúdos ensinados pelo professor.

Você poderá testar seus conhecimentos através das atividades do Material, descobrindo o quanto já aprendeu durante as aulas e o que ainda falta para aprender.

Este Material é seu e não precisa ser devolvido ao final do ano, mas, é preciso ter cuidado para não perdê-lo ou estragá-lo, para que você possa usá-lo durante todo o semestre.

Outra boa notícia é que você vai poder levar o Material para casa e poderá rever o que aprendeu e estudar mais um pouco, com certeza você vai ficar craque em conhecimento.

SECRETARIA DE
EDUCAÇÃO



MEU NOME É:

HOJE É DIA:



GÊNERO TEXTUAL: POEMA

A ÁGUA

A

A ÁGUA É MINHA AMIGA
COM ELA POSSO CONTAR
PRA LAVAR E TOMAR BANHO
E MINHA SEDE MATAR
VAMOS TODOS PROTEGÊ-LA
E A NATUREZA CUIDAR
RESGATAR SUA IMPORTÂNCIA
PARA ELA NÃO FALTAR

(autor desconhecido)

PINTE DE AZUL TODAS AS LETRAS A QUE APARECEM NO TEXTO.

CUIDAR DA ÁGUA É MUITO IMPORTANTE, ELA É NECESSÁRIA PARA BEBER, TOMAR BANHO E COZINHAR. É POSSÍVEL TAMBÉM FAZER EXPERIÊNCIA COM ELA! VAMOS VER?

INSTRUÇÕES: DESENHE O QUE QUISER NO ESPAÇO AO LADO. COLOQUE-O ATRÁS DO COPO DE VIDRO. EM SEGUIDA, ENCHA O COPO DE ÁGUA. E OBSERVE O QUE ACONTECE!

CONVERSE COM SEUS COLEGAS SOBRE O QUE ACONTECEU.



LIGUE OS PONTOS PARA VER QUAL INSETO IRÁ APARECER!

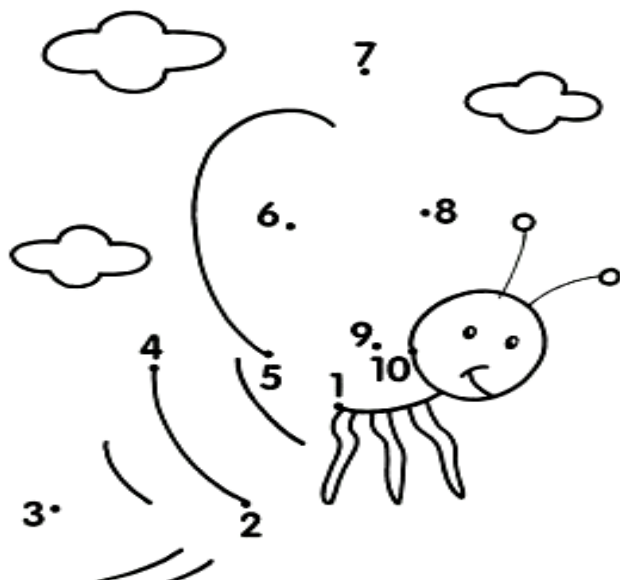

COM QUE LETRA COMEÇA O NOME DO INSETO QUE VOCÊ DESCOBRIU?

PINTE AS PALAVRAS QUE COMEÇAM COM A LETRA **A** E LIGUE AO DESENHO CORRESPONDENTE.

ABÓBORA

ESTRELA

ABACATE

OLHO



VAMOS TREINAR?

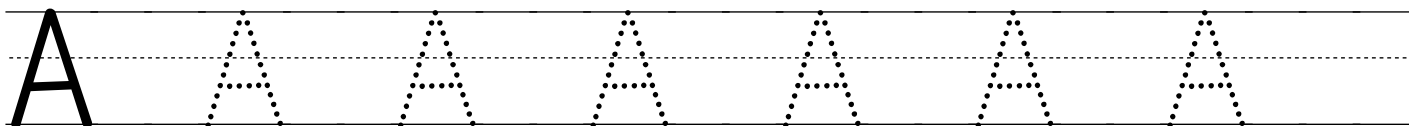

PINTE E ESCREVA NAS LINHAS ABAIXO O NOME DAS FIGURAS QUE COMEÇAM COM A LETRA A.

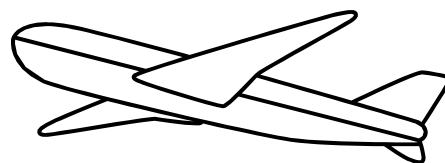
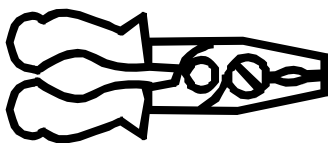
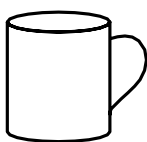
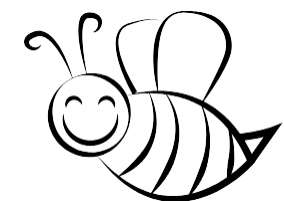

FALE O NOME DAS FIGURAS, PERCEBA QUANTAS VEZES ABRIMOS A BOCA AO PRONUNCIÁ-LAS, REGISTRE O NÚMERO E PINTE UMA BOLINHA PARA CADA SÍLABA. COMO NO EXEMPLO DO AVIÃO.

| | | | |
|--|------------|--|--------------|
| | AVIÃO ●●●○ | | ABÓBORA ○○○○ |
| | ANEL ○○○○ | | APITO ○○○○ |
| | ARARA ○○○○ | | ABELHA ○○○○ |

MEU NOME É:

HOJE É DIA:

| | |
|--|--|
| | |
|--|--|



GÊNERO TEXTUAL: BILHETE

E

| | |
|--|------------------------------|
| | 20/07/2019 |
| | EDUARDA, |
| | ESTAMOS ESPERANDO VOCÊ PARA |
| | BRINCAR NO ESCORREGADOR NOVO |
| | DA ESCOLA. |
| | MELHORE LOGO! |
| | BEIJOS. |
| | BETE |
| | |

CIRCULE A LETRA E QUE ENCONTRAR NAS PALAVRAS DO BILHETE.

REESCREVA AS PALAVRAS DO TEXTO QUE COMEÇAM COM A LETRA E

| | | |
|--|--|--|
| | | |
| | | |

CUBRA O PONTILHADO E CONTINUE NA LINHA ABAIXO:





E E E E E E E

| |
|--|
| |
| |
| |



PRODUZA, JUNTO COM SUA TURMA, A RESPOSTA DO BILHETE ENVIADO A EDUARDA.

SIGA O EXEMPLO.



| DESENHO | PALAVRA | LETRA INICIAL | QUANTAS VEZES ABRIMOS A BOCA PARA FALAR |
|---|---------------------|---------------|---|
|  | ESQUILO | E | 3 |
|  | ESCORREGADOR | | |
|  | ESPADA | | |
|  | ESTRELA | | |
|  | ESCADA | | |

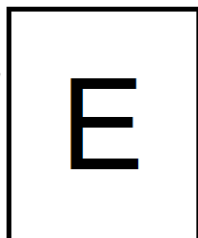
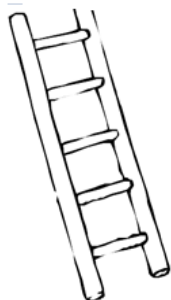
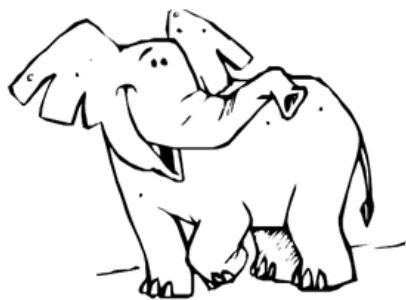

LIGUE OS DESENHOS QUE COMEÇAM COM A VOGAL E.



COMPLETE OS NOMES DAS FIGURAS COM A LETRA E, DEPOIS COPIE AO LADO.

| | | |
|---|-----------|-------|
|  | __N XAD A | _____ |
|  | P__T__CA | _____ |
|  | __STO JO | _____ |

MEU NOME É:

HOJE É DIA:

| | |
|--|--|
| | |
|--|--|



GÊNERO TEXTUAL: MÚSICA

INDIOZINHOS

UM, DOIS, TRÊS INDIOZINHOS
QUATRO, CINCO, SEIS INDIOZINHOS
SETE, OITO, NOVE INDIOZINHOS
DEZ NO PEQUENO BOTE.
IAM NAVEGANDO PELO RIO ABAIXO
QUANDO O JACARÉ SE APROXIMOU E
O PEQUENO BOTE DOS INDIOZINHOS
QUASE, QUASE VIROU... MAS NÃO
VIROU!

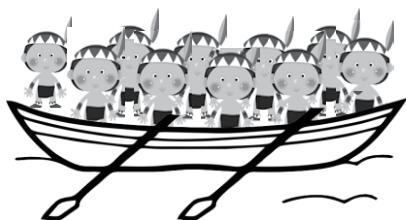

SUBLINHE TODAS AS LETRAS **I** QUE VOCÊ ENCONTRAR NA MÚSICA.

OBA! HORA DA DOBRADURA!

APÓS FAZER A DOBRADURA DO BARCO, COLE NO CADERNO DE DESENHO.
USE SUA CRIATIVIDADE PARA FAZER O CENÁRIO.

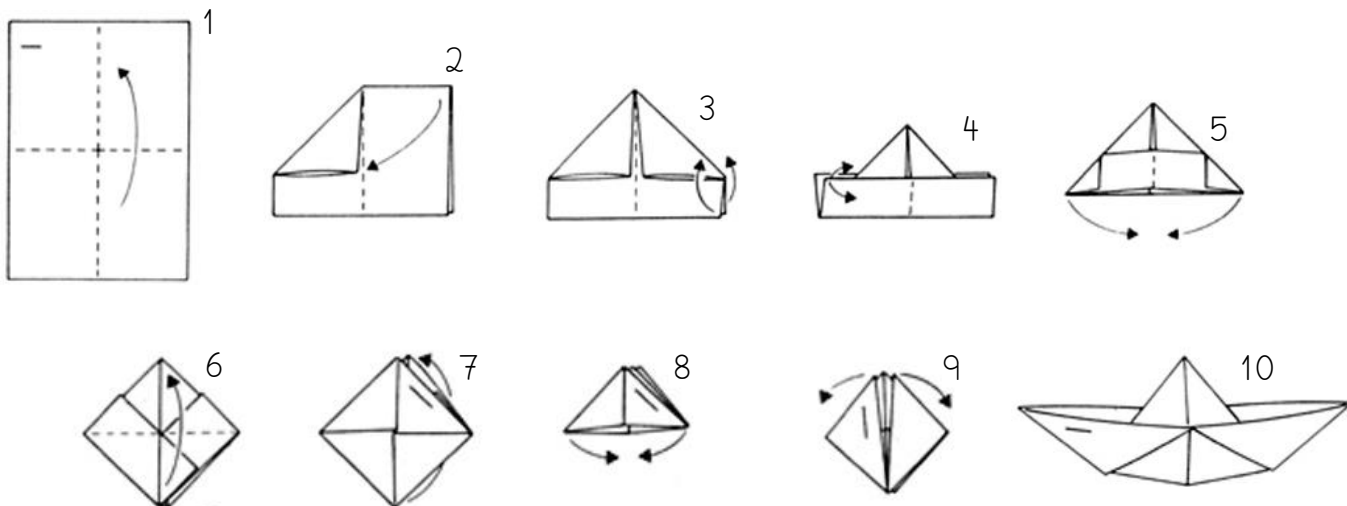

O INDIOZINHO QUER VER SE VOCÊ JÁ SABE FAZER A LETRA I, CUBRA O PONTILHADO E CONTINUE NA LINHA ABAIXO.



Tracing practice lines for the letter 'I'. The first row shows a solid vertical line followed by a dotted vertical line, with a solid line starting from the dotted one. Below this are two more rows of solid horizontal lines with a dotted horizontal line in between, for independent practice.

CONSULTE O BANCO DE PALAVRAS E ESCREVA O NOME DAS FIGURAS.

| | | |
|-------------|---------------|----------------|
| IMÃ | ILHA | ÍNDIO |
| IOIÔ | IGREJA | INJEÇÃO |

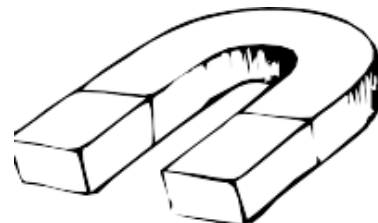

PINTE DE AZUL A FIGURA QUE COMEÇA COM A LETRA **I** E DE AMARELO A FIGURA QUE TERMINA.

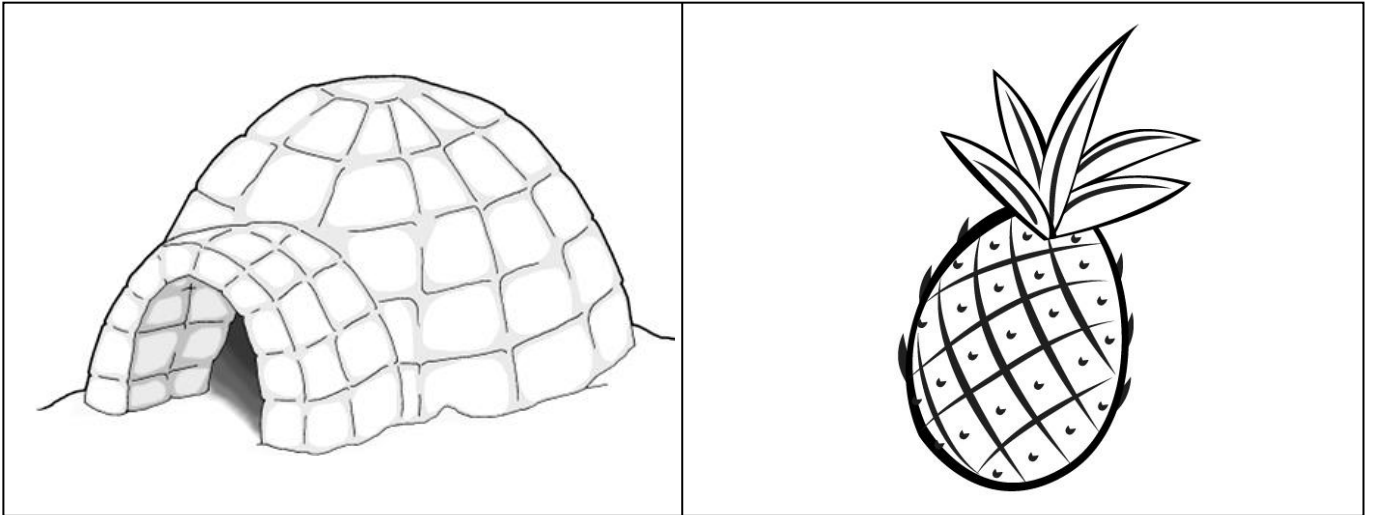

PESQUISE QUAIS NOMES DOS COLEGAS DA SUA SALA POSSUEM A LETRA **I**, PODE SER NO COMEÇO, MEIO OU NO FIM. AGORA REGISTRE ABAIXO.

A large rectangular box containing ten horizontal lines for writing, intended for recording names of classmates that start or end with the letter 'I'. The bottom right corner of the box is folded over like a page corner.

MEU NOME É:

HOJE É DIA:

| | |
|--|--|
| | |
|--|--|



GÊNERO TEXTUAL: ADIVINHA

O



O QUE É? O QUE É?
 “QUAL É A COISA,
 QUAL É ELA, QUE É
 BRANCA E CAINDO
 NO CHÃO FICA
 AMARELA?”
 (autor desconhecido)

RESPOSTA



PINTE DE AMARELO AS LETRAS O QUE ENCONTRAR NA ADIVINHA.

A ARTISTA PLÁSTICA TARSILA DO AMARAL PINTOU UMA OBRA CHAMADA “URUTU” CONHECIDA COMO O OVO. FAÇA SUA RELEITURA PINTANDO A OBRA DO SEU JEITO.

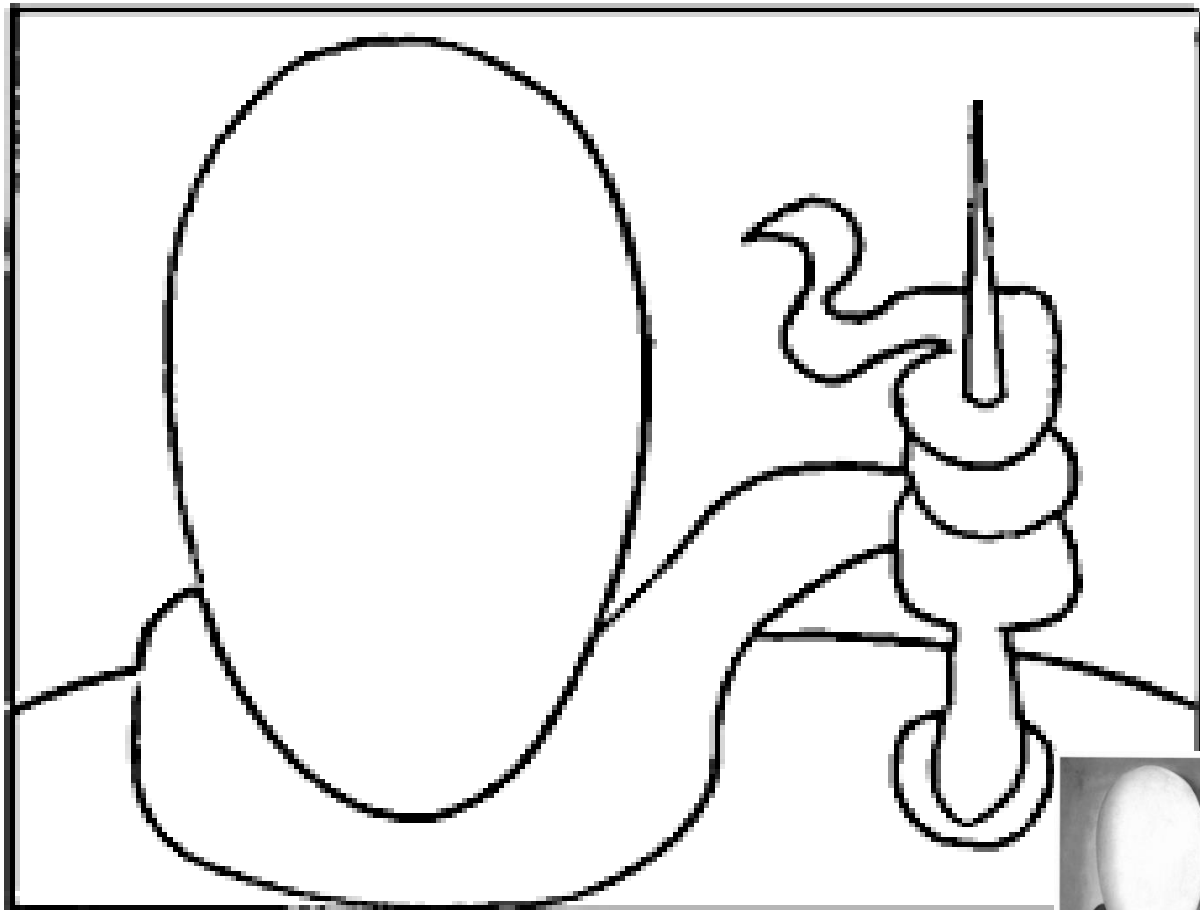

PESQUISE EM REVISTAS E JORNAIS PALAVRAS QUE INICIEM COM A LETRA O RECORTE E COLE NO QUADRO ABAIXO.

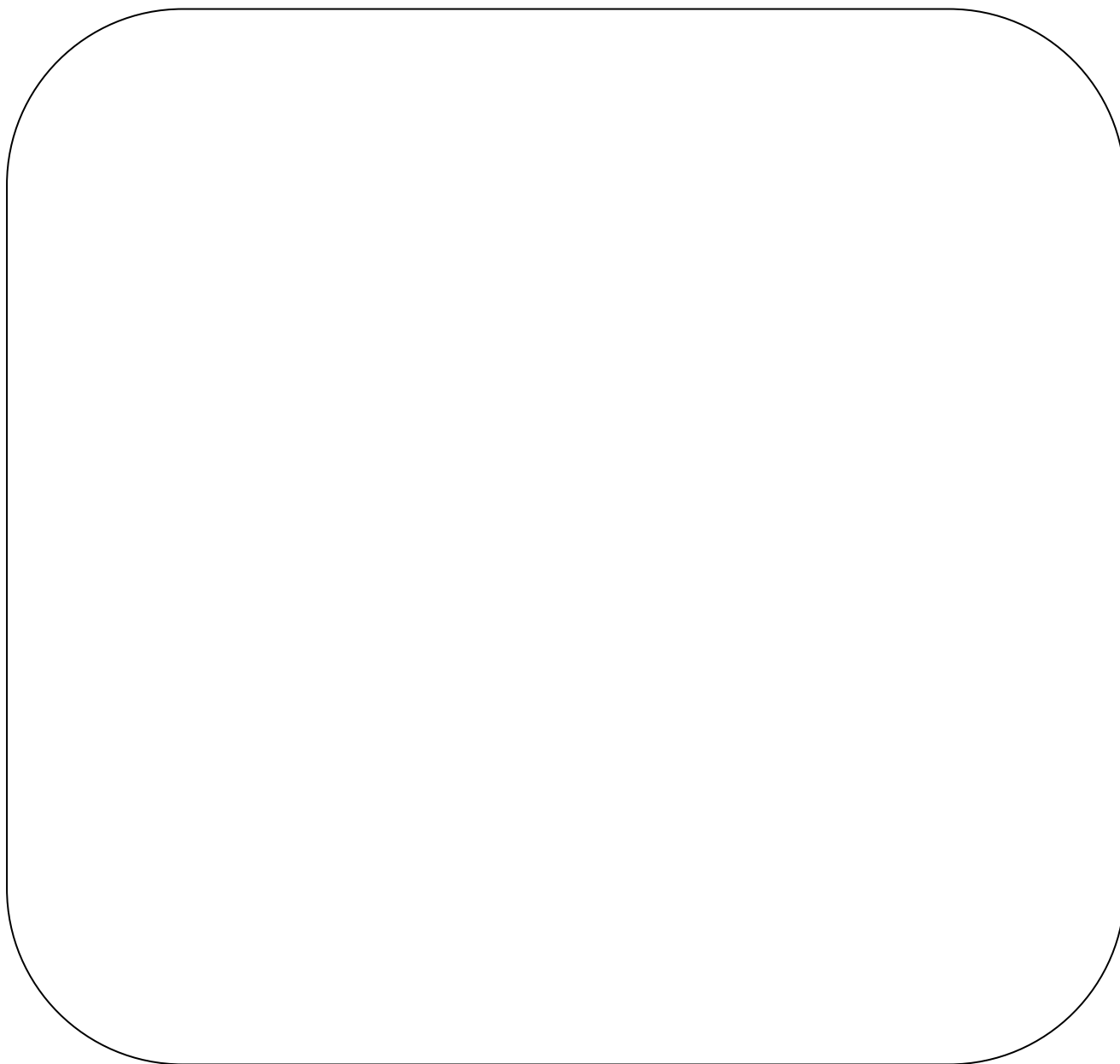

CUBRA O PONTILHADO:

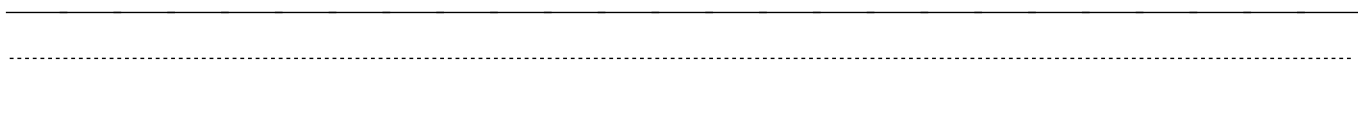
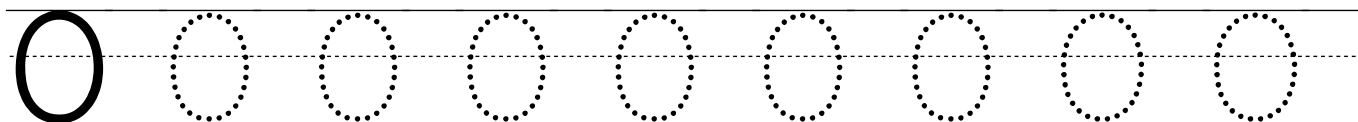

MEU NOME É:

HOJE É DIA:

| | |
|--|--|
| | |
|--|--|



GÊNERO TEXTUAL: NOTÍCIA

URSO É FLAGRADO BRINCANDO EM PULA-PULA EM QUINTAL DE CASA NOS EUA

U

UMA AMERICANA FILMOU UM URSO BRINCANDO EM UM PULA-PULA NO QUINTAL DE SUA CASA. AMY FOSTER, POSTOU IMAGENS DO ANIMAL PULANDO NO BRINQUEDO, ANTES DE CORRER DE VOLTA PARA O MATO.



ELA DISSE QUE AS GARRAS DO URSO ESTRAGARAM A CAMA ELÁSTICA.

Fonte: <https://g1.globo.com/planeta-bizarro/noticia/urso>

PINTE TODAS AS LETRAS **U** QUE ENCONTRAR NO TEXTO.

CIRCULE AS PALAVRAS QUE TERMINAM COM A LETRA **U**.

| | | | | |
|--------|---------|--------|--------|--------|
| CAVALO | PANELA | GORILA | URUBU | ESCOVA |
| ÍNDIO | BONECA | ZEBU | FIVELA | BAÚ |
| CHUCHU | ENFEITE | CUECA | XÍCARA | COLAR |

CUBRA O PONTILHADO.

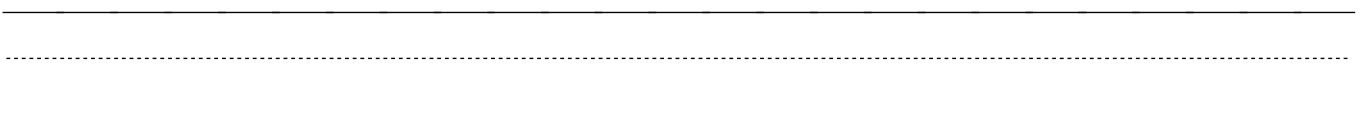
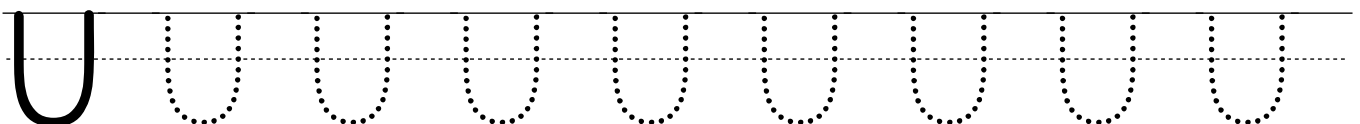

CRIE COLETIVAMENTE UMA NOTÍCIA BEM LEGAL SOBRE ESSA IMAGEM E REGISTRE ABAIXO.

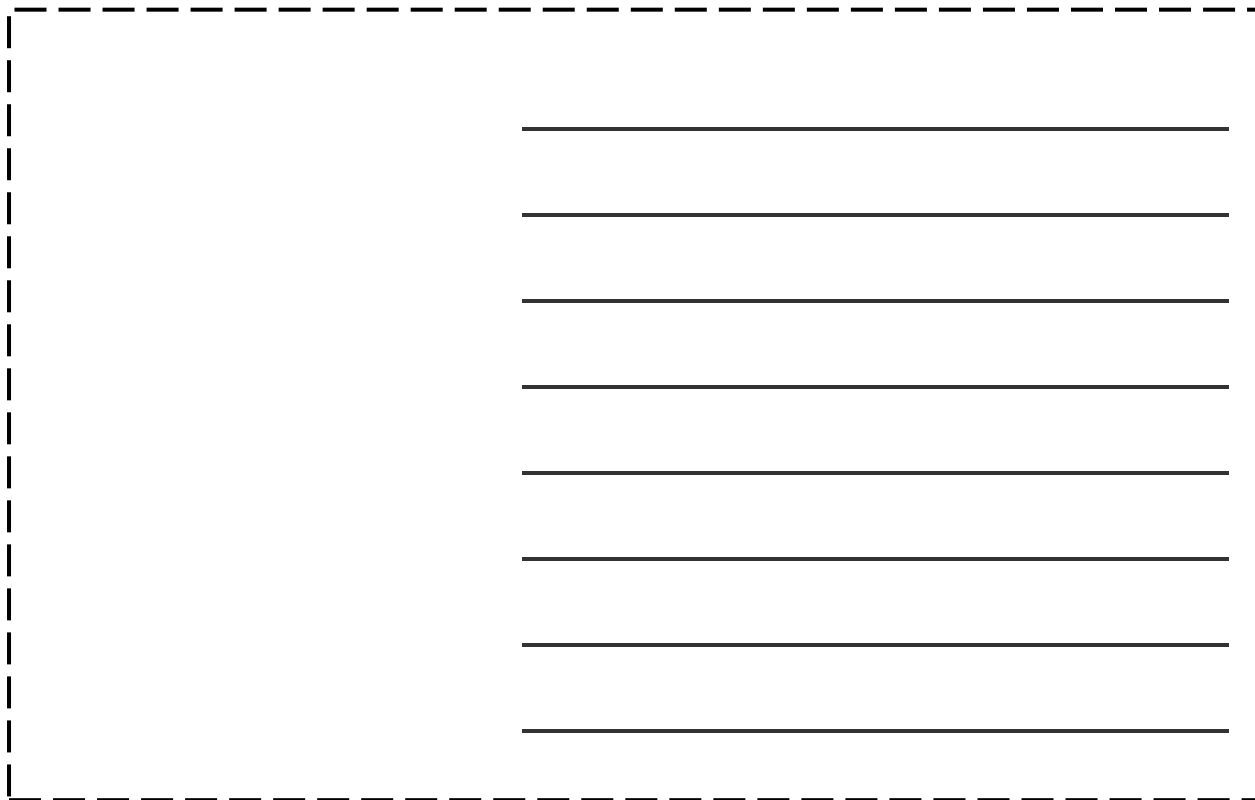

FAÇA UM DESENHO CUJO NOME COMECE COM A LETRA U.

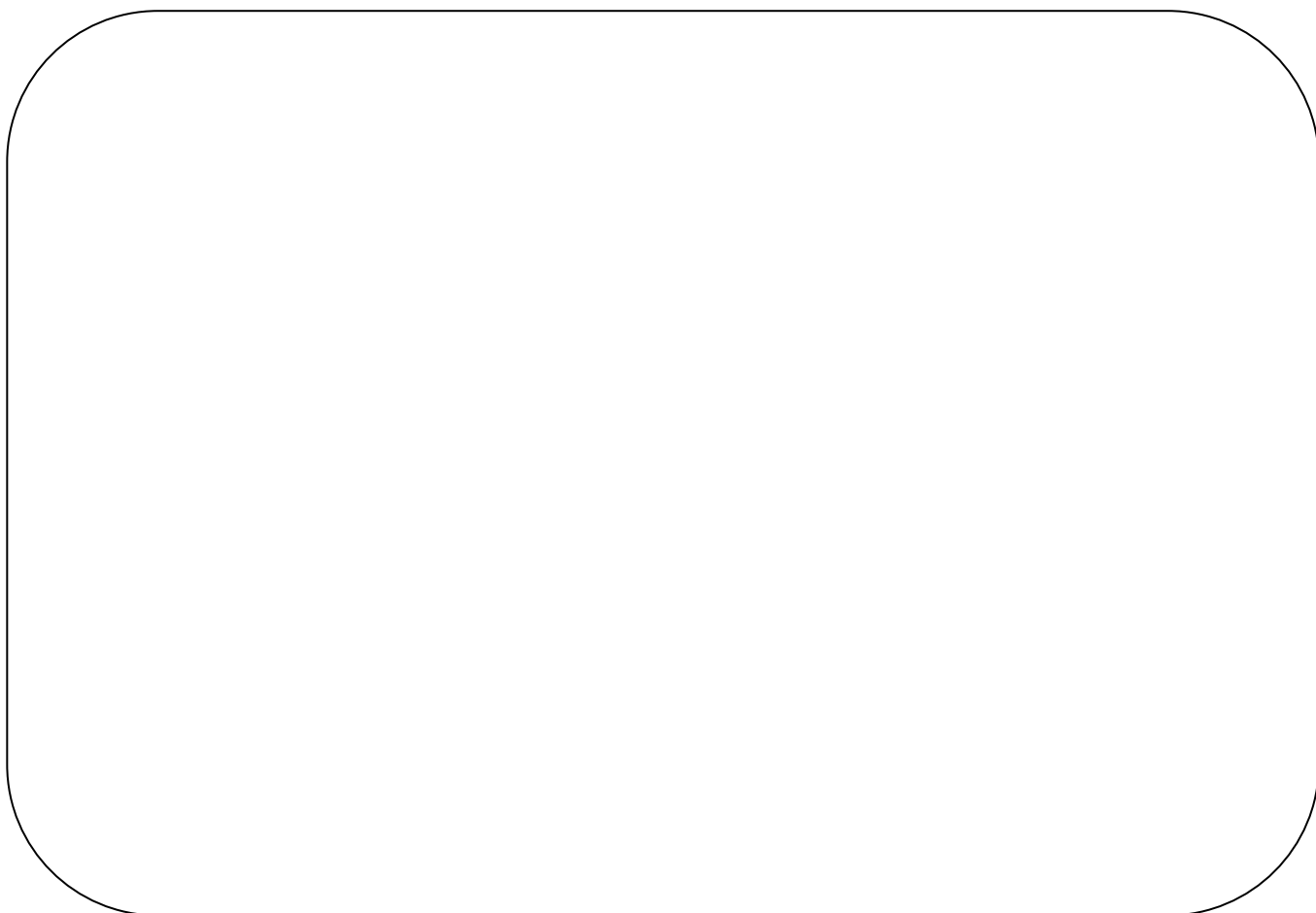

MEU NOME É:

HOJE É DIA:

| | |
|--|--|
| | |
|--|--|

VAMOS VER SE VOCÊ JÁ CONHECE AS VOGAIS? LIGUE AS COLUNAS A VOGAL CORRESPONDENTE.



I

O

A

U

E

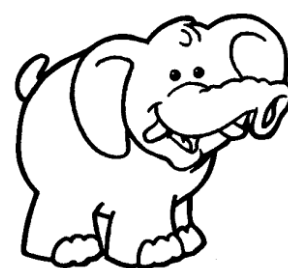

OBSERVE OS QUADRINHOS E COMPLETE COM OS ENCONTROS VOCÁLICOS.

AI – OI – UI – EI

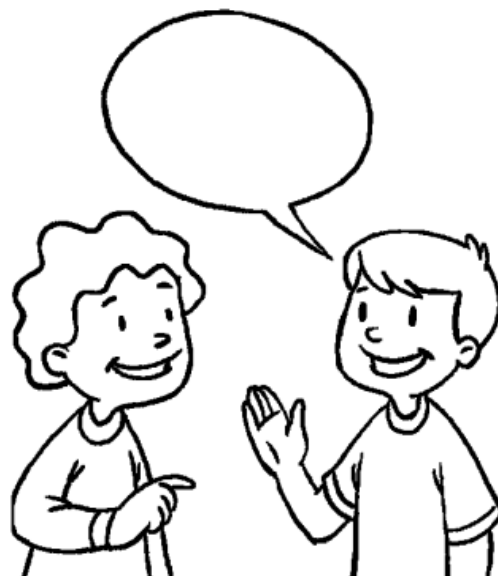

PINTE DE AMARELO OS ENCONTROS VOCÁLICOS QUE A PROFESSORA FOR DITANDO.

| | | | |
|-----------|-----------|-----------|-----------|
| AI | UI | AU | OI |
| EU | IA | OU | EI |



ONOMATOPEIAS SÃO PALAVRAS QUE TENTAM IMITAR, SONS, RUÍDOS E MOVIMENTOS PRODUZIDOS POR ANIMAIS, OBJETOS OU FENÔMENOS NATURAIS. RECORTE AS FIGURAS DA PÁGINA 61, IMITE OS SONS E COLE NOS ESPAÇOS CORRETOS.

AU AU

BUÁ

BI BI

BÉÉÉ

MIAU

TIC TAC







MUUUU

OINC OINC

PIU PIU

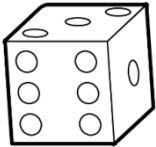
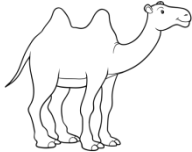

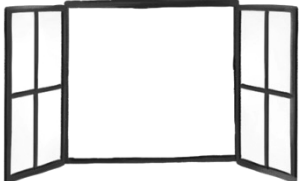
COMPLETE AS PALAVRAS COM AS VOGAIS E REGISTRE COPIANDO AO LADO.

| | | |
|---|--------------|------|
|  | B <u>OLA</u> | BOLA |
|  | L_Ç_ | |
|  | B_N_C_ | |
|  | D_D_ | |
|  | C_M_L_ | |
|  | C_L_ | |
|  | J_N_L_ | |
|  | B_L_CH_ | |
|  | C_N_T_ | |



MEU NOME É:

HOJE É DIA:

| | |
|--|--|
| | |
|--|--|



A BORBOLETA

DONA LAGARTINHA
DO OVO SAIU
COMEU, ENGORDOU
PRA VIDA PARTIU!

DONA LAGARTINHA
COM SONO FICOU
ENTROU NO CASULO
E SE ENROSCOU!

O TEMPO PASSOU
O RELÓGIO CORREU
UMA LINDA BORBOLETA
DO CASULO APARECEU

DONA LAGARTINHA AGORA
BORBOLETA
COM AS BELAS ASAS
DE COR VIOLETA

ISABEL CRISTINA S. SOARES

GÊNERO TEXTUAL: POEMA

B



CIRCULE NO TEXTO TODAS AS PALAVRAS **BORBOLETA** QUE ENCONTRAR.
ILUSTRE O POEMA DESENHANDO AS ASAS DA BORBOLETA.

A LAGARTINHA SE TRANSFORMOU NUMA LINDA BORBOLETA.
NUMERE DE ACORDO COM O PROCESSO DE TRANSFORMAÇÃO

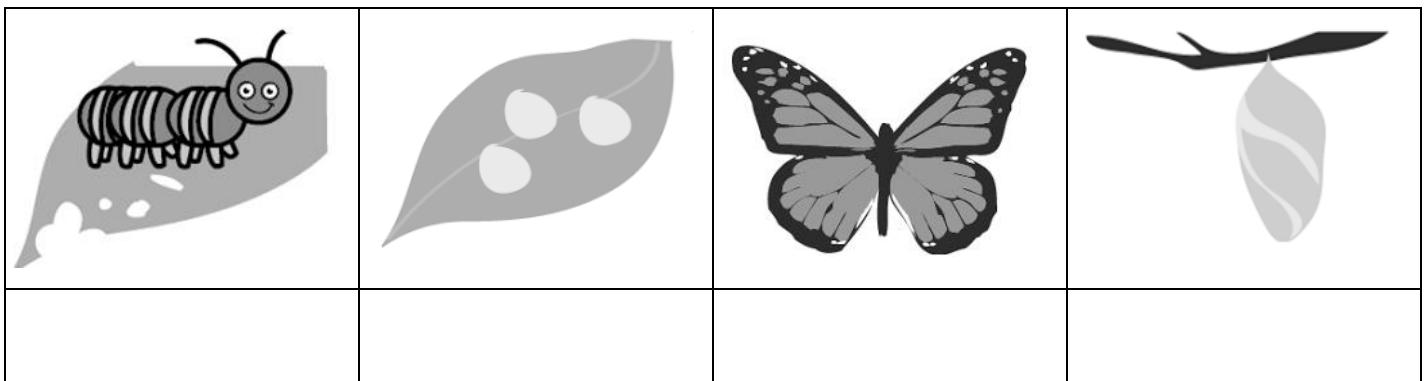

RECORTE O ANEXO DA PÁGINA 63 E FAÇA UM LINDO DEDOCHE DE
BORBOLETA! USE A IMAGINAÇÃO E SAIA VOANDO POR AÍ!



DESCUBRA NA POESIA PALAVRAS QUE RIMAM COM AS PALAVRAS EM DESTAQUE E PINTE-AS.

| | | | |
|------------------|-----------|-----------|----------|
| BORBOLETA | BONITAS | VIOLETA | PANELAS |
| CORREU | APARECEU | BORBOLETA | LUZ |
| FICOU | ESCURIDÃO | BRANCAS | ENROSCOU |

CUBRA OS PONTILHADOS:

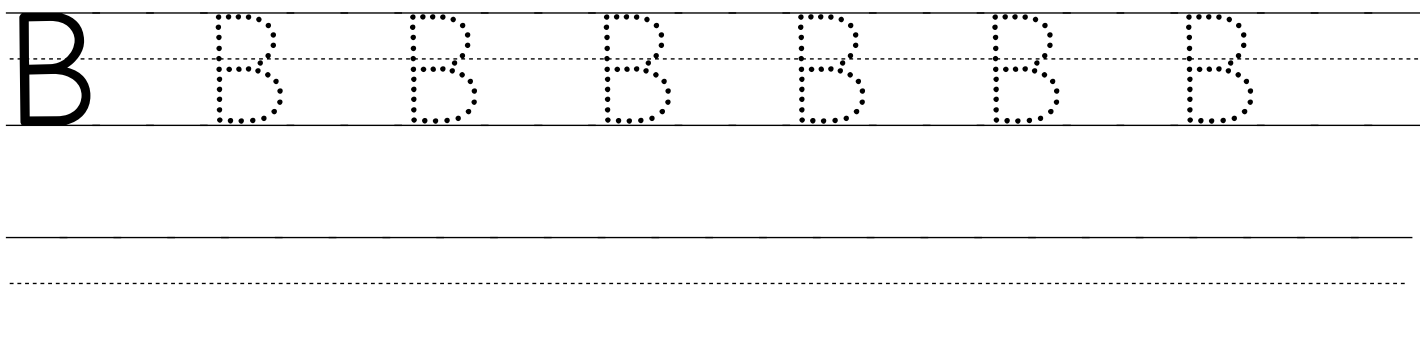

ESCREVA O NOME DAS FIGURAS.





















MEU NOME É:

HOJE É DIA:

| | |
|--|--|
| | |
|--|--|



GÊNERO TEXTUAL: CONVITE

C

CONVITE

CONVIDO VOCÊ PARA COMEMORAR O MEU ANIVERSÁRIO, QUE ACONTECERÁ NO DIA 11 DE ABRIL ÀS 17 HORAS
LOCAL: RUA CARIJÓS Nº 1.500, VILA TUPI
CONTO COM SUA PRESENÇA!

VAMOS TREINAR?

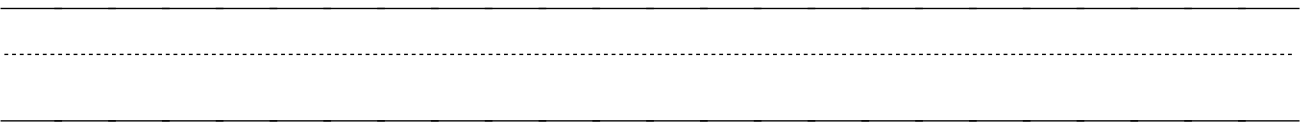
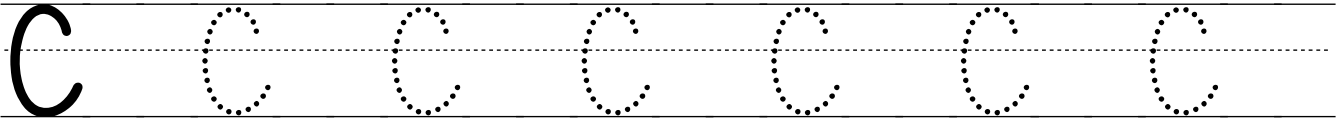

COPIE DO TEXTO PALAVRAS QUE COMEÇAM COM A LETRA C.



CIRCULE O NOME DA FIGURA E COPIE AO LADO.



L C A N G U R U L S



Z L U A C U E C A L

CRIE UM CONVITE COLETIVO COM SUA TURMA. PODE SER UM CONVITE PARA O DIA DO BRINQUEDO, DIA DO PARQUE, DIA DO CINEMINHA NA ESCOLA E CAPRICHE!

CONVITE

VAMOS LER ESTA PARLENDA!

A CASINHA DA VOVÓ,
CERCADINHA DE CIPÓ,
O CAFÉ ESTÁ DEMORANDO,
COM CERTEZA NÃO TEM PÓ.

(autor desconhecido)



PINTE O QUADRINHO COM A RESPOSTA CORRETA.

A CASINHA É:

DA MAMÃE

DO PAPAÍ

DA VOVÓ

DA TITIA



MEU NOME É:

HOJE É DIA:

| | |
|--|--|
| | |
|--|--|



GÊNERO TEXTUAL: REGRA DO JOGO

DOMINÓ

D

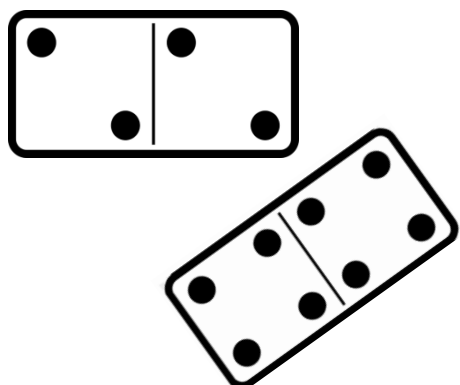

PARA JOGAR COM 2 OU 4 JOGADORES CADA JOGADOR DEVE FICAR COM 7 PEÇAS. NA PRIMEIRA RODADA QUEM TIVER A MAIOR PEÇA COMEÇA O JOGO. CADA UM DEVE TENTAR ENCAIXAR EM UMA DE SUAS PEÇAS NAS EXTREMIDADES DO JOGO, QUANDO O JOGADOR CONSEGUE ENCAIXAR UMA PEÇA, PASSA PARA O COLEGA, CASO NÃO CONSIGA ENCAIXAR UMA PEÇA, DEVE COMPRAR NO MONTE, SE NÃO HOVER PEDRAS PARA O ENCAIXE, PASSARÁ A VEZ. O JOGO ACABA QUANDO ALGUÉM FICA SEM PEÇAS NA MÃO.

CIRCULE AS LETRAS **D** QUE ENCONTRAR NO TEXTO DO DOMINÓ

RECORTE AS PEÇAS DE DOMINÓ DA PÁGINA 65 E DIVIRTA-SE COM SEUS COLEGAS!

PINTE AS BOQUINHAS DE ACORDO COM O NÚMERO DE SÍLABAS DAS PALAVRAS ABAIXO.

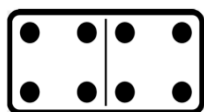

DOMINÓ



DEDO



DINOSSAURO



DENTE



CUBRA OS PONTILHADOS E CONTINUE NA LINHA ABAIXO:

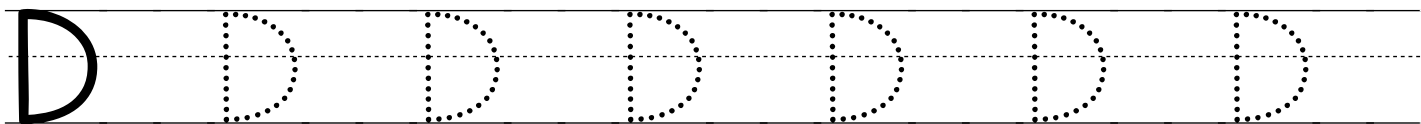

PINTE E ESCREVA NAS LINHAS ABAIXO O NOME DAS FIGURAS QUE COMEÇAM COM A LETRA D.

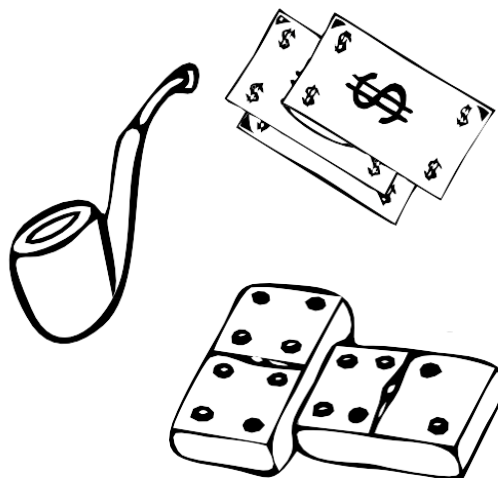

PINTE UM QUADRADINHO PARA CADA SÍLABA DA PALAVRA.



DESPERTADOR

| | | | | | |
|--|--|--|--|--|--|
| | | | | | |
|--|--|--|--|--|--|



DINHEIRO

| | | | | | |
|--|--|--|--|--|--|
| | | | | | |
|--|--|--|--|--|--|



DOENTE

| | | | | | |
|--|--|--|--|--|--|
| | | | | | |
|--|--|--|--|--|--|



MEU NOME É:

HOJE É DIA:

| | |
|--|--|
| | |
|--|--|



GÊNERO TEXTUAL: MANUAL DE INSTRUÇÃO

O FEIJÃOZINHO

PLANTANDO FEIJÃO NO POTINHO!

PRIMEIRO VOCÊ PRECISA UMEDECER O ALGODÃO COM A ÁGUA E FORRAR O FUNDO DO COPO COM ESTE ALGODÃO.

COLOQUE SEU FEIJÃO SOBRE O ALGODÃO, PONHA O COPO EM UM LOCAL ILUMINADO E NÃO DEIXE O ALGODÃO SECAR.

EM MAIS OU MENOS EM 3 DIAS, A RAIZ COMEÇARÁ A APARECER E UM POUCO MAIS TARDE SEU FEIJÃO VAI COMEÇAR A NASCER.

AGORA, CUIDADO PARA NÃO ENCHARCAR O ALGODÃO, É NECESSÁRIO APENAS UMEDECÊ-LO.

QUANDO O FEIJÃO ATINGIR CERCA DE 15 CM, É A HORA DE COLOCAR TERRA.

F

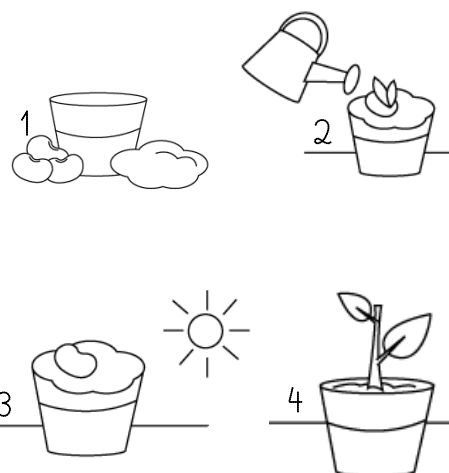

SUBLINHE AS LETRAS F QUE ENCONTRAR NO TEXTO.









VAMOS RELEMBRAR A HISTÓRIA DO JOÃO E O PÉ DE FEIJÃO?

JOÃO PLANTOU FEIJÕES MÁGICOS QUE CRESCERAM ATÉ CHEGAR A UM CASTELO NAS NUVENS!

VÁ ATÉ A PÁGINA 63, PINTE O CASTELO, RECORTE E COLE NUM PALITO DE CHURRASCO. ESPETE NA TERRA DO FEIJÃOZINHO QUE VOCÊ PLANTOU. ELE FICARÁ ASSIM!!



PINTE A FIGURA QUE COMEÇA COM O MESMO SOM QUE O NOME DO DESENHO EM DESTAQUE.

| | | |
|--|---|---|
|  <p>FAMÍLIA</p> |  |  |
|  <p>FECHADURA</p> |  |  |
|  <p>FOGO</p> |  |  |

LIGUE CADA FIGURA À PALAVRA CORRESPONDENTE:



FUSCA



FÓSFORO



FUNIL

VAMOS TREINAR?

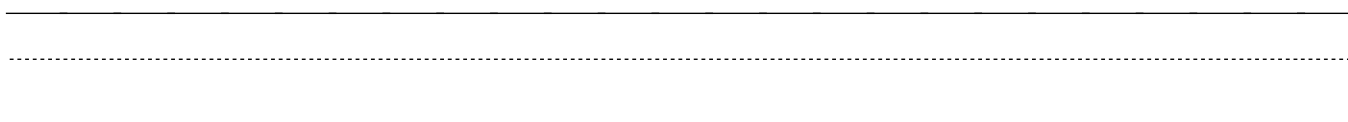
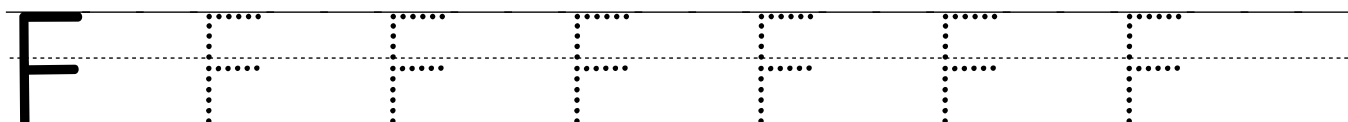

ESCREVA O NOME DAS FIGURAS ABAIXO COMO SOUBER:

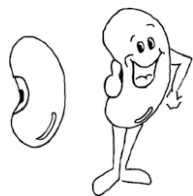

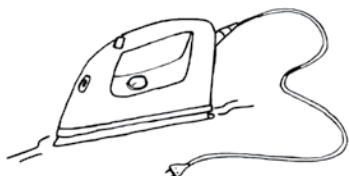

LIGUE AS PALAVRAS QUE COMEÇAM COM O MESMO SOM:

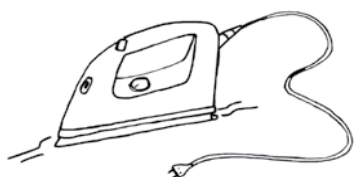
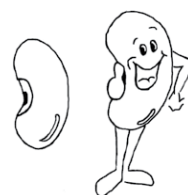

MEU NOME É:

HOJE É DIA:

| | |
|--|--|
| | |
|--|--|



GÊNERO TEXTUAL: BIOGRAFIA

GUSTAVO ROSA

G

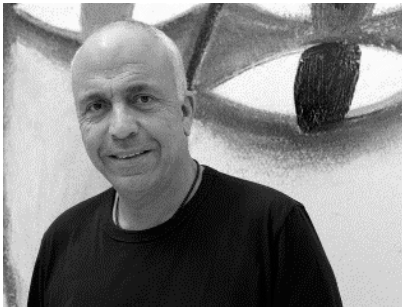

FOI UM ARTISTA PLÁSTICO, NASCIDO EM SÃO PAULO EM 20 DE DEZEMBRO DE 1946, ONDE VEIO A FALECER EM 12 DE NOVEMBRO DE 2013. COSTUMAVA DIZER QUE NASCEU DESENHANDO. SUA MÃE DIZIA QUE AOS TRÊS ANOS DE IDADE, FICAVA DE BRUÇOS NO CHÃO, DESENHANDO VÁRIAS IMAGENS EM BLOCOS DE PAPEL, QUANDO NÃO AS FAZIAM NAS PAREDES DE CASA E CADERNOS ESCOLARES.

GUSTAVO ROSA GOSTAVA DE DESENHAR GATOS. SEUS GATOS ERAM COLORIDOS, BEM HUMORADOS E COM UMA INFLUÊNCIA CUBISTA.

RECORTE O ANEXO DA PÁGINA 67, MONTE A OBRA: "GATO" E COLE NO SEU CADERNO DE DESENHO.



A PALAVRA GATO COMEÇA COM A LETRA **G**, TREINE O PONTILHADO E CONTINUE NA LINHA ABAIXO

G G G G G G G



CRUZADINHA

GIRASSOL
GARFO
GRILO
GALO

A crossword puzzle grid is shown. The vertical word is "GIRASSOL" and the horizontal word is "GARFO". The letters are placed in the grid as follows: G (row 1, col 3), I (row 2, col 3), R (row 3, col 3), A (row 4, col 3), S (row 5, col 3), S (row 6, col 3), O (row 7, col 3), L (row 8, col 3). The horizontal word "GARFO" is placed in row 4, starting from column 2. Illustrations of a sunflower, a grasshopper, a fork, and a rooster are placed next to their respective letters in the grid.

PINTE AS FIGURAS QUE COMEÇAM COM O MESMO SOM QUE A PALAVRA **GATO**.

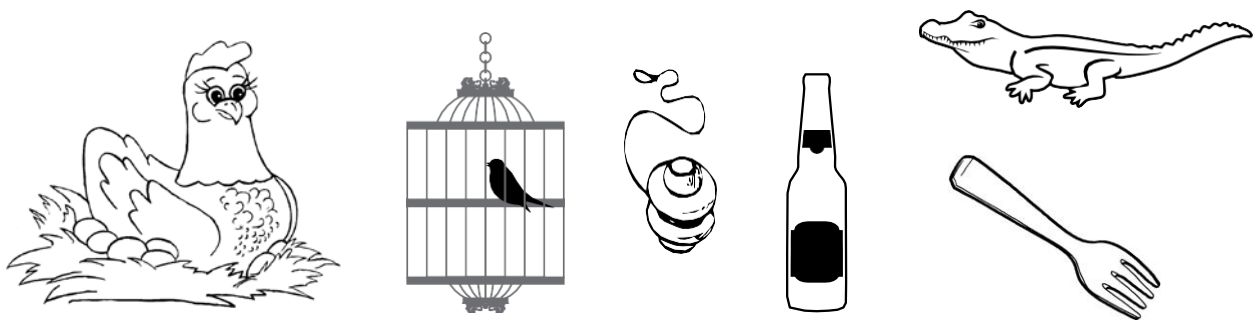

ESCREVA O NOME DAS FIGURAS QUE VOCÊ PINTOU.



MEU NOME É:

HOJE É DIA:

| | |
|--|--|
| | |
|--|--|



GÊNERO TEXTUAL: MANUAL DE INSTRUÇÃO

HORTA DE PET

VAMOS FAZER UMA HORTA COLETIVA?



MATERIAL:

- 1 TAMPA DE CAIXA DE OVO (DÚZIA)
- 1 GARRAFA PET
- TESOURA SEM PONTA
- TERRA
- SEMENTES (ESCOLHA DA TURMA)

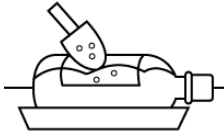

H

COMO MONTAR:

1. DEITE A GARRAFA PLÁSTICA E CORTE UM RETÂNGULO NA PARTE SUPERIOR. FAÇA PEQUENOS FURINHOS NA BASE. 
2. COLOQUE TERRA DENTRO DA GARRAFA E COLOQUE SEU VASO SOBRE A TAMPA DA CAIXA DO OVO. ELA VAI ABSORVER A ÁGUA QUE ESCORRER. 
3. ENTERRE AS SEMENTINHAS COBRINDO BEM. 
4. PRONTO! VOCÊ JÁ TEM SUA PRÓPRIA HORTA. 
5. PARA A PLANTA CRESCER BASTANTE, É IMPORTANTE REGAR E DEIXÁ-LA EM UM LUGAR AREJADO.

(Fonte desconhecida)

OBSERVANDO O CRESCIMENTO DE SUA PLANTA.
VÁ ATÉ O ANEXO DA PÁGINA 69 RECORTE E COLE NO SEU CADERNO DE DESENHO A SEQUÊNCIA LÓGICA OBSERVADA.



CUBRA O PONTILHADO E CONTINUE NA LINHA ABAIXO.

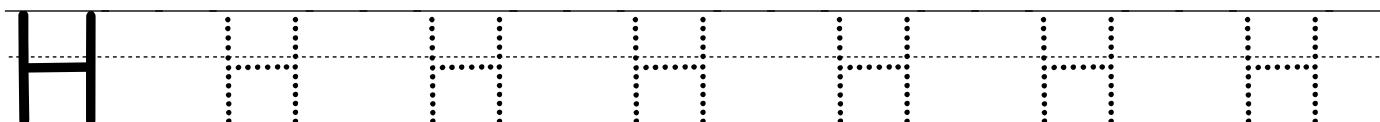

COMPLETE OS NOMES DAS FIGURAS COM A LETRA H DEPOIS COPIE AO LADO.

| | | |
|--|--------|--|
|  | _ÉLICE | |
|  | _IENA | |
|  | _ARPA | |

PINTE UM CÍRCULO PARA CADA SÍLABA DA PALAVRA.

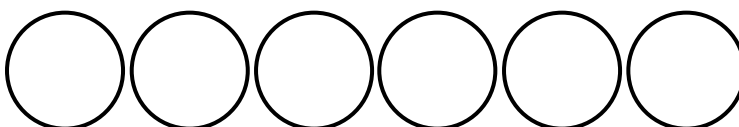
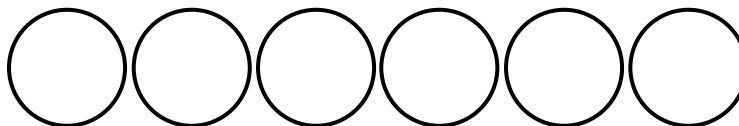
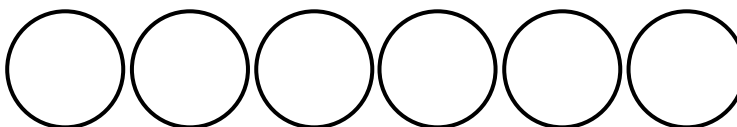
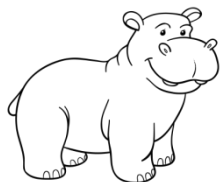
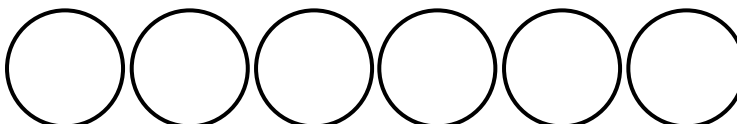

MEU NOME É:

HOJE É DIA:

| | |
|--|--|
| | |
|--|--|



GÊNERO TEXTUAL: POEMA

OS BICHINHOS

A JOANINHA, TÃO BONITINHA,
QUEBROU SUA ASINHA
O JACARÉ, QUE MANÉ, TINHA CHULÉ
A JIBOIA ADORAVA UMA JOIA
E O JABUTI? NÃO ESTAVA NEM AÍ.

(Autor desconhecido)

J

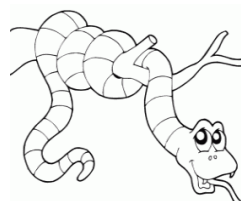
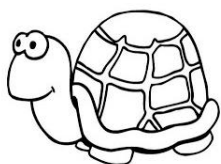

RESPONDA

QUEM QUEBROU A ASINHA?

QUEM TINHA CHULÉ?

QUEM GOSTAVA DE JOIA?

QUEM NÃO ESTAVA NEM AÍ?

VAMOS CANTAR A MÚSICA DO JACARÉ?

TROQUE AS PALAVRAS EM DESTAQUE E DIVIRTA-SE!

EU CONHEÇO UM JACARÉ
QUE GOSTA DE COMER
ESCONDAM SEUS OLHINHOS
SENÃO O JACARÉ
COME SEUS **OLHINHOS** E O DEDÃO DO PÉ

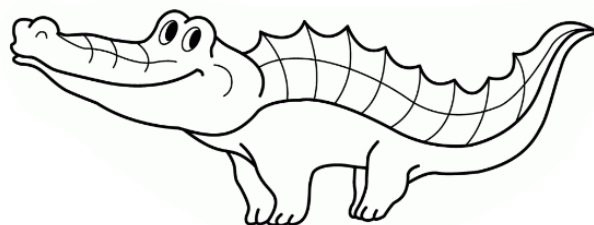

EU CONHEÇO UM JACARÉ
QUE GOSTA DE COMER
ESCONDAM SUAS ORELHAS
SENÃO O JACARÉ
COME SUAS **ORELHAS** E O DEDÃO DO PÉ



PINTE A PALAVRA CORRESPONDENTE AO DESENHO.

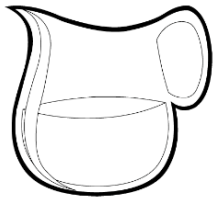

MACACO

JARRA

CAMELO

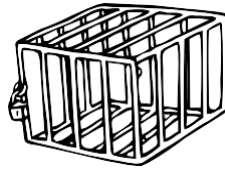

BANANA

JAULA

CASA

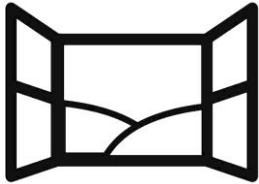

DADO

JANELA

MESA

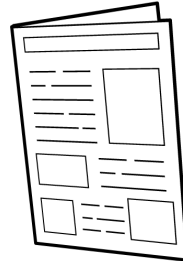

URUBU

JORNAL

SAPO

SUBLINHE AS PARTES DAS PALAVRAS ABAIXO.

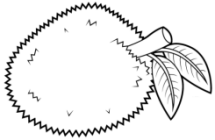

JACA



JABUTICABA



JIPE

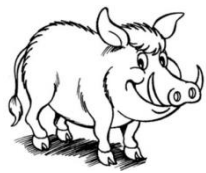

JAVALI

VAMOS TREINAR?

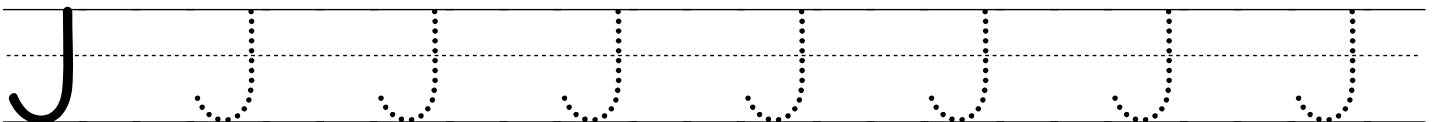

MEU NOME É:

HOJE É DIA:

| | |
|--|--|
| | |
|--|--|



GÊNERO TEXTUAL: INFORMATIVO

KIWI

K

É UMA FRUTA DE ORIGEM CHINESA, CONSIDERADA UMA DAS FRUTAS COM MAIOR QUANTIDADE DE VITAMINA C. POSSUI UM SABOR LEVEMENTE AZEDO. É MUITO USADO PARA A FABRICAÇÃO DE SUCOS E SORVETES.

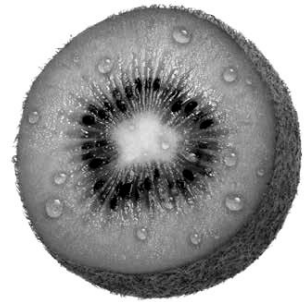

VOCÊ JÁ EXPERIMENTOU KIWI?

FAÇA UMA DEGUSTAÇÃO COM SUA TURMA.

AGORA RESPONDA E PINTE A FRUTA DE ACORDO COM SUA OBSERVAÇÃO:

QUAL A COR DE FORA?

QUAL A COR DE DENTRO?

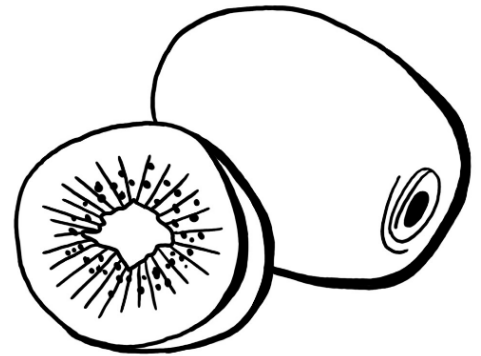

CUBRA O PONTILHADO.

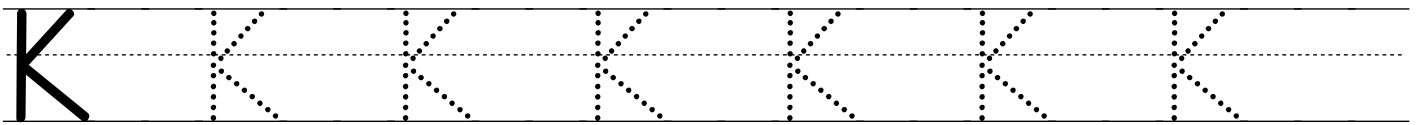



CONTE QUANTAS LETRAS TÊM AS PALAVRAS E REGISTRE AS QUANTIDADES NOS QUADROS.



KIMONO

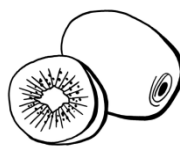

KIWI



KOMBI



KARINA



KART

ESCREVA A INICIAL DE CADA DESENHO E DESCUBRA AS PALAVRAS SURPRESA.

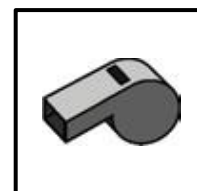
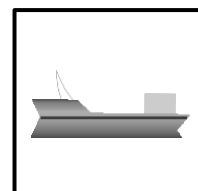
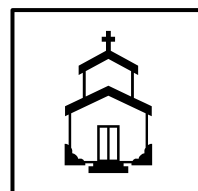
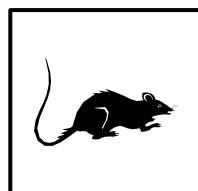
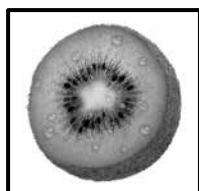

MEU NOME É:

HOJE É DIA:

| | |
|--|--|
| | |
|--|--|

NÚMERO **1**.

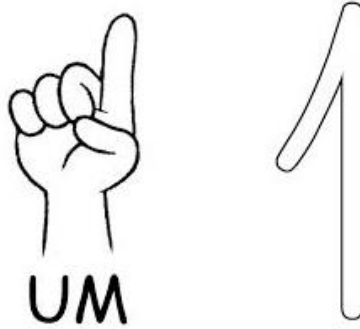

DESENHE 1 ELEMENTO DENTRO DOS CONJUNTOS:



PINTE AS IMAGENS QUE POSSUEM APENAS 1 ELEMENTO:

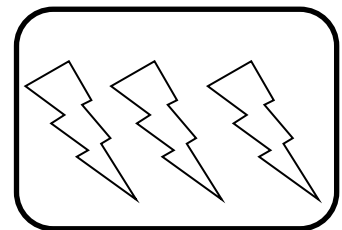
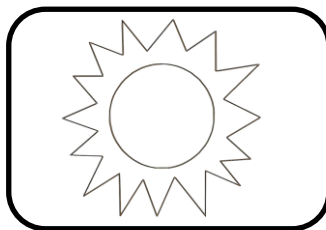
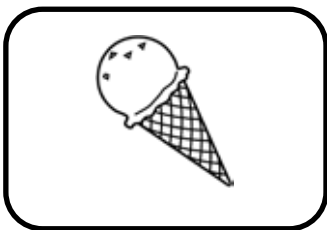
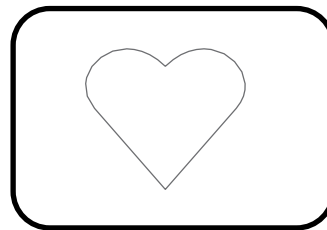
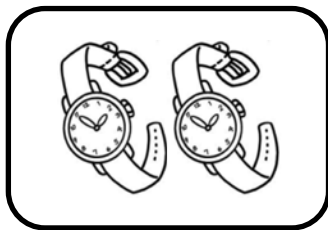

VAMOS TREINAR?

1 - 1

OBSERVE A CENA:



QUANTAS CRIANÇAS ESTÃO EM CIMA DA ÁRVORE?

QUANTAS CRIANÇAS ESTÃO EMBAIXO DA ÁRVORE?

VAMOS CONTAR?

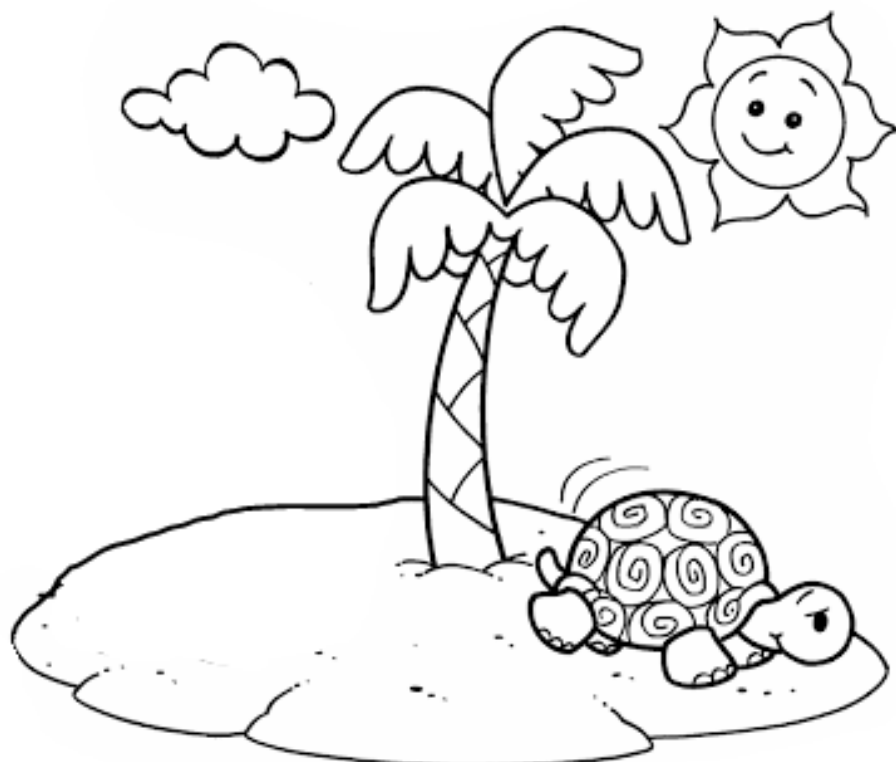
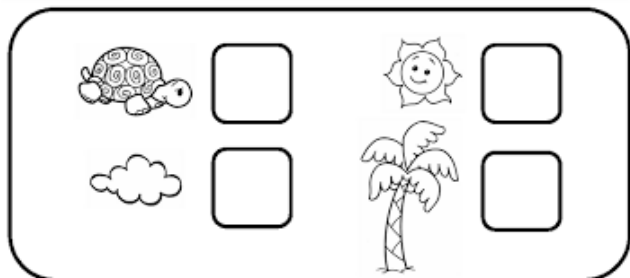

MEU NOME É:

HOJE É DIA:

| | |
|--|--|
| | |
|--|--|

NÚMERO 2

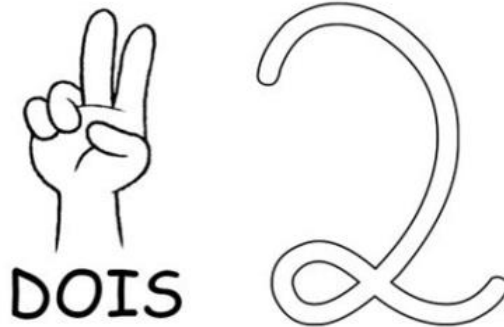

REGISTRE A QUANTIDADE CORRESPONDENTE.

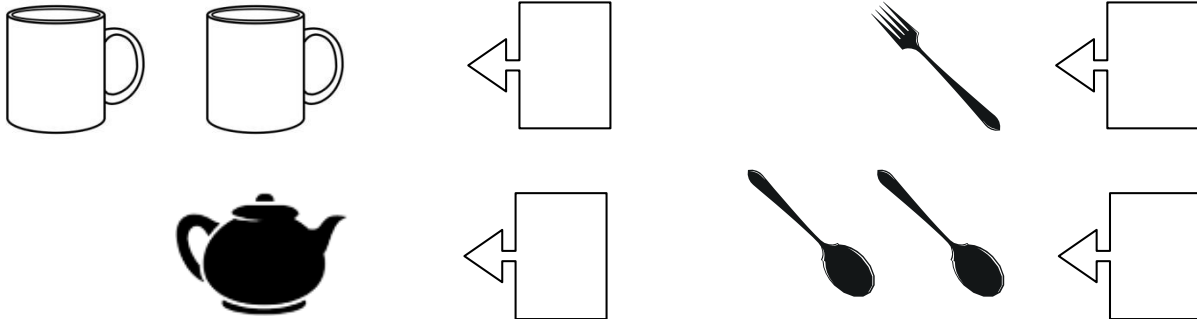

PINTE APENAS OS CONJUNTOS QUE POSSUEM 2 IMAGENS.



CUBRA O PONTILHADO E CONTINUE:

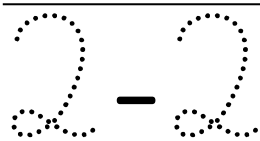

DESENHE 1 PORTA E 2 JANELAS NA CASINHA. EM SEGUIDA, DESENHE O JARDIM DA CASA.

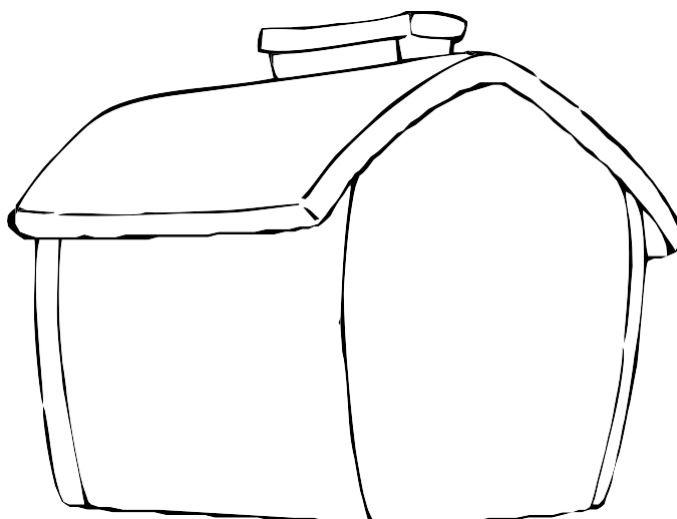

OBSERVE A CENA E RESPONDA:

| | | |
|--------------------------------|------------------------------|-------------------------------------|
| | | |
| <p>___PATINHO ESTÁ NADANDO</p> | <p>CHEGOU MAIS___PATINHO</p> | <p>AGORA SÃO___PATINHOS NADANDO</p> |

ESTE SOU EU...

EU TENHO_____OLHOS.

EU TENHO_____NARIZ.

EU TENHO_____ORELHAS.

EU TENHO_____PESCOÇO.

EU TENHO_____BRAÇOS.

EU TENHO_____UMBIGO.

EU TENHO_____PERNAS.

EU TENHO_____MÃOS

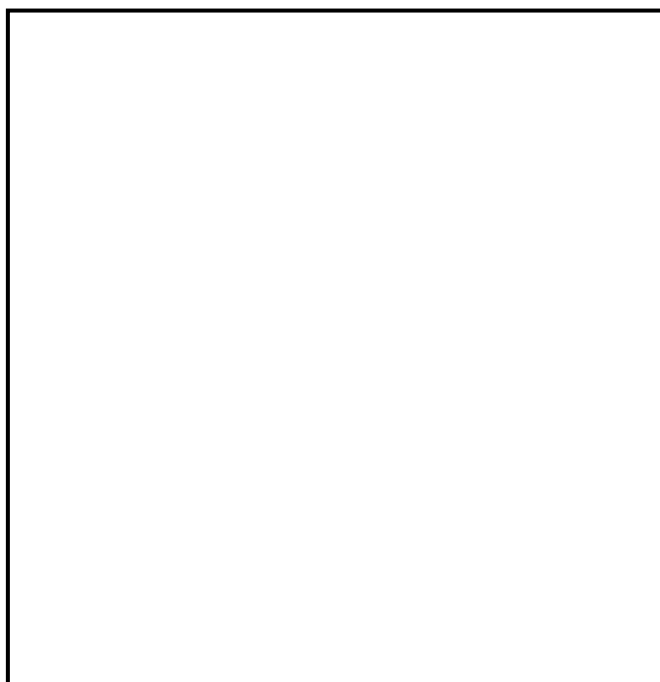

MEU NOME É:

HOJE É DIA:

| | |
|--|--|
| | |
|--|--|



NÚMERO 3



TRÊS



OBSERVE A FIGURA E RESPONDA:

| | | |
|--|---|----------------------|
| | QUANTAS  ? | <input type="text"/> |
| | QUANTOS  ? | <input type="text"/> |
| | QUANTAS  ? | <input type="text"/> |

PINTE AS CAMISETAS COM O NÚMERO 3.



VAMOS TREINAR?

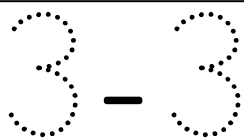

CONTINUE A SEQUÊNCIA:

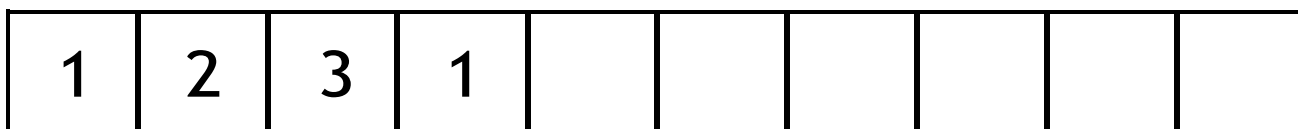
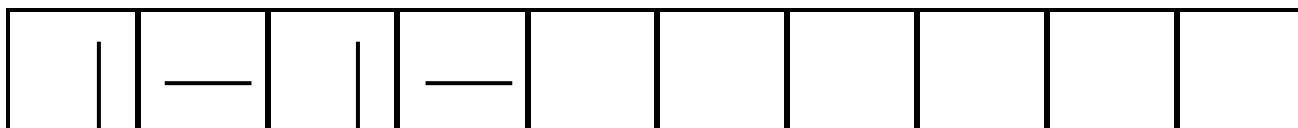
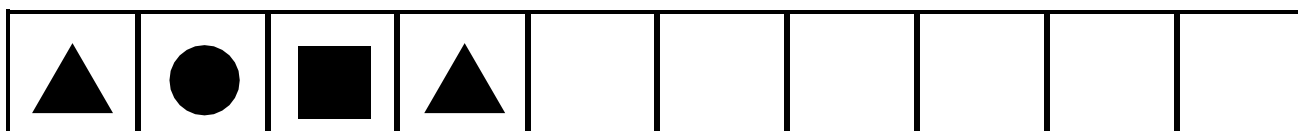
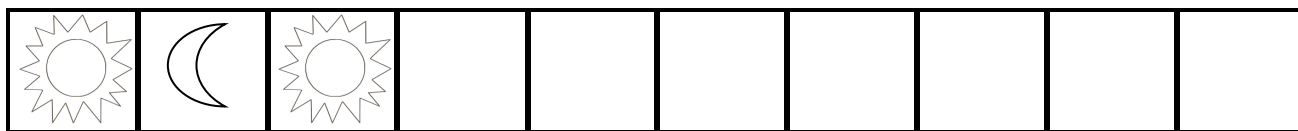

INVENTE OUTRA SEQUÊNCIA.

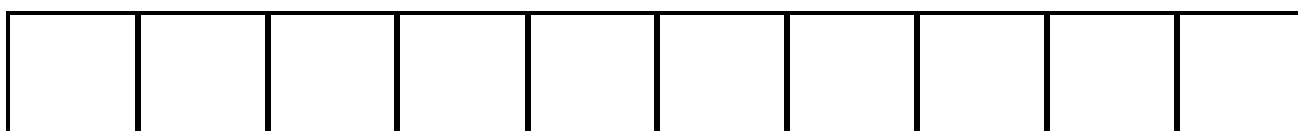

PINTE A BERMUDA MAIS COMPRIDA.

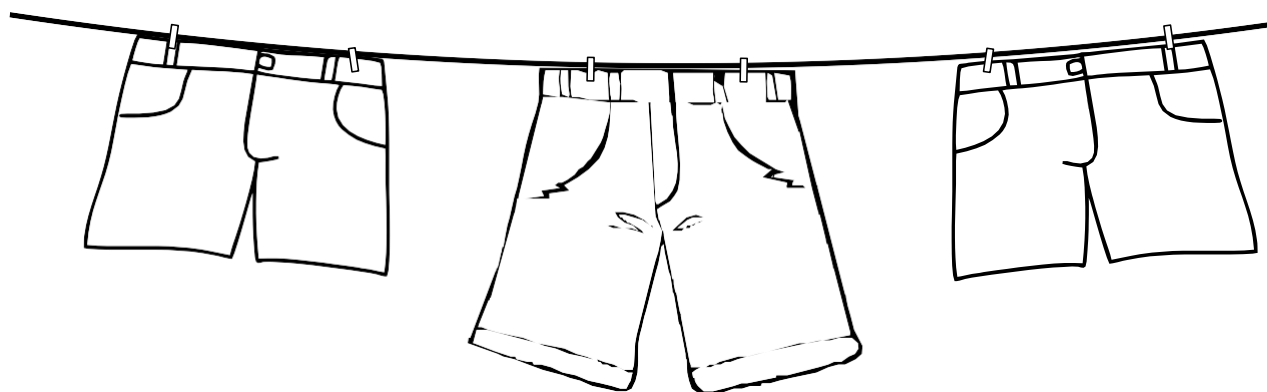

MEU NOME É:

HOJE É DIA:

| | |
|--|--|
| | |
|--|--|

NÚMERO 4

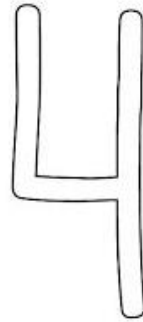

QUATRO

RELACIONE O NÚMERO A QUANTIDADE:

2



4



1

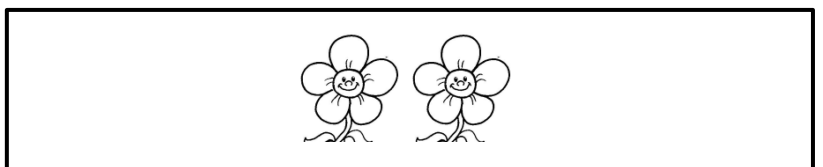

3

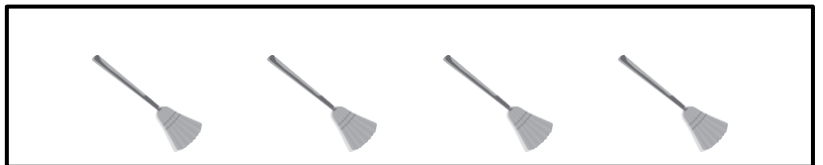

CUBRA O PONTILHADO E CONTINUE AO LADO:

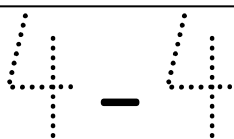

PESQUISE, RECORTE E COLE NO RETÂNGULO ABAIXO 4 FIGURAS.

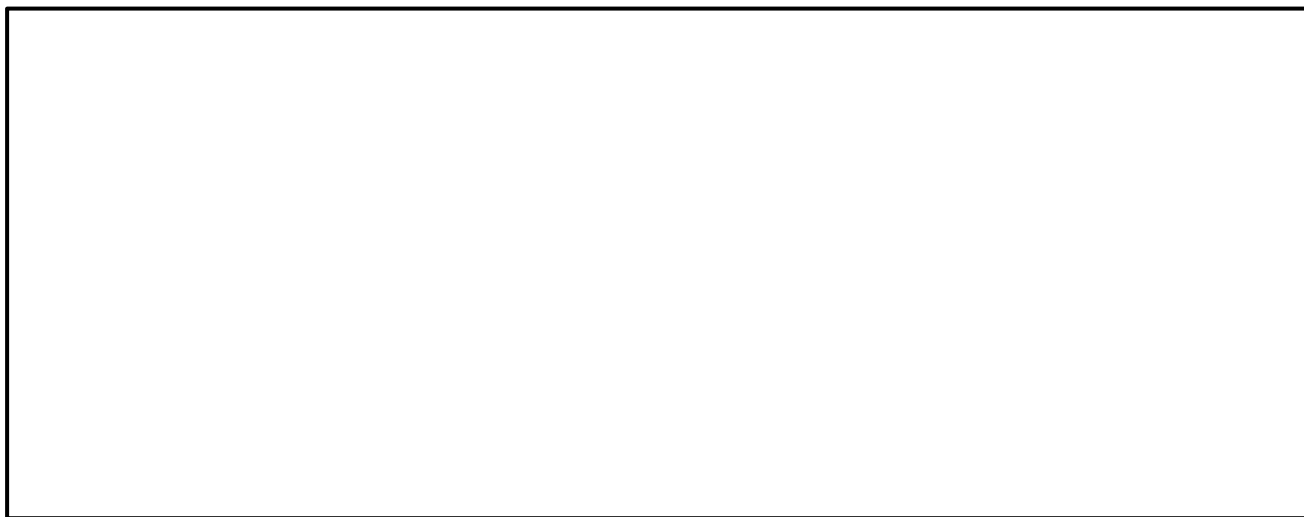

ESCREVA NO O NÚMERO CORRESPONDENTE DE FORMIGAS.



DESENHE O QUE SE PEDE.



4

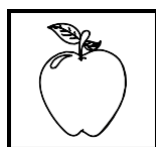

3



MEU NOME É:

HOJE É DIA:

| | |
|--|--|
| | |
|--|--|

NÚMERO 5

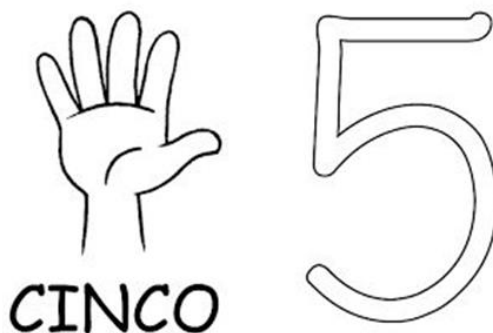

CINCO

LIGUE O NUMERAL AO CONJUNTO CORRESPONDENTE.

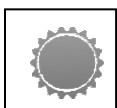

2

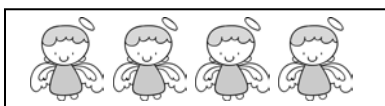
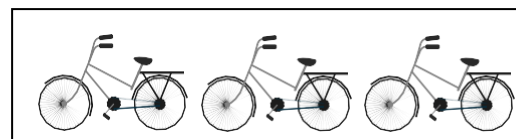

5

1

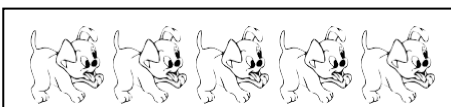
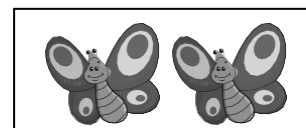

3

4

RESOLVA O PROBLEMINHA:

| | | |
|--------------------------------|-------------------|----------------------------|
| | | |
| SÃO ___ GATINHOS TOMANDO LEITE | ___ JÁ TERMINARAM | AINDA FICARAM ___ GATINHOS |

VAMOS TREINAR?

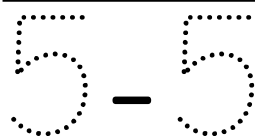

CIRCULE OS CONJUNTOS QUE POSSUEM 5 ITENS.

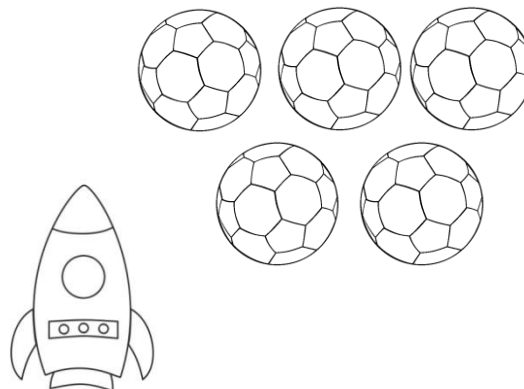
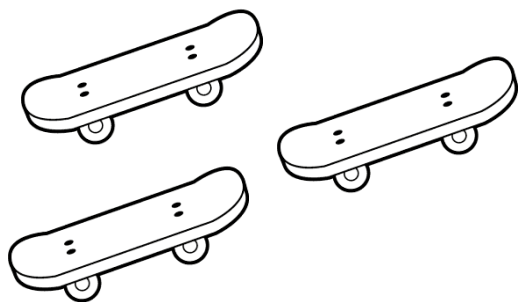
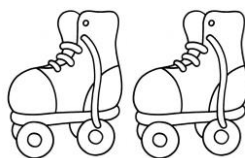
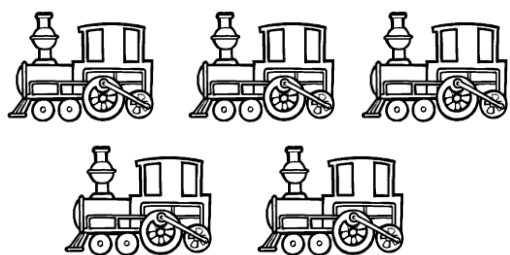

RESOLVA O PROBLEMINHA:

| | | |
|---------------------------|------------------------------------|------------------------------|
| | | |
| <p>HAVIA _____ FLORES</p> | <p>MAS MURCHARAM _____ FLORES.</p> | <p>FIGARAM _____ FLORES.</p> |

REGISTRE O NUMERAL CONFORME A QUANTIDADE CORRESPONDENTE.

| | |
|--|--|
| | |
| | |
| | |
| | |
| | |

MEU NOME É:

HOJE É DIA:

| | |
|--|--|
| | |
|--|--|

NÚMERO 6

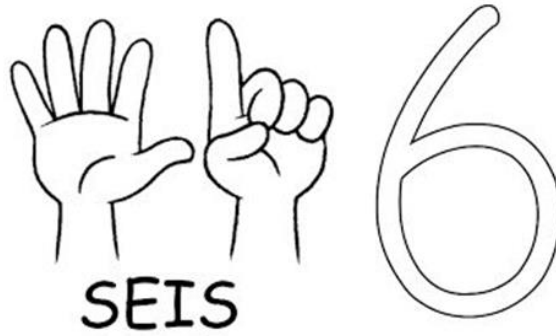

LIGUE A QUANTIDADE DOS OBJETOS AO NUMERAL CORRESPONDENTE.



6



5



4



2

ESCREVA NAS ETIQUETAS A QUANTIDADE DE CADA CONJUNTO.

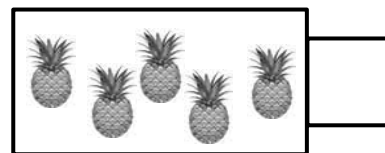
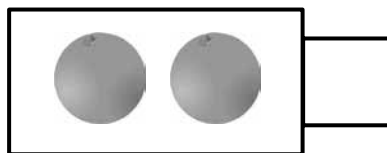
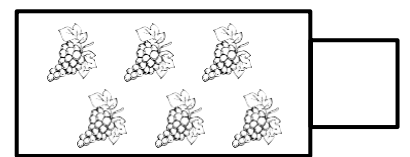
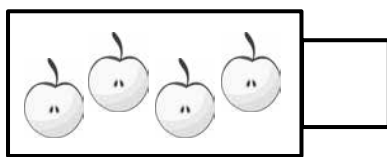

CUBRA O PONTILHADO E CONTINUE AO LADO:

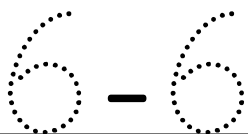





DESENHE A QUANTIDADE DE OBJETOS DE ACORDO COM O NÚMERO INDICADO:

| | | |
|---|---|---|
| | | |
| 5 | 4 | 2 |
| | | |
| 1 | 3 | 6 |

OBSERVE A CENA:



REGISTRE A QUANTIDADE DE ELEMENTOS ABAIXO.

| | |
|---|--|
|  | |
|  | |
|  | |
|  | |

MEU NOME É:

HOJE É DIA:

| | |
|--|--|
| | |
|--|--|

NÚMERO **7**

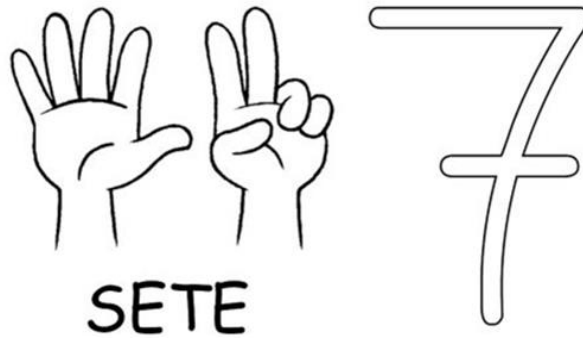

SETE

COMPLETE PARA QUE TODOS OS CONJUNTOS TENHAM 7 ELEMENTOS.

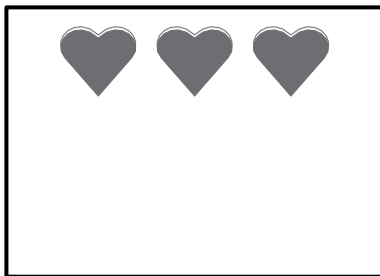

7

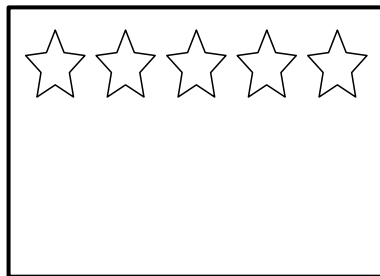

7

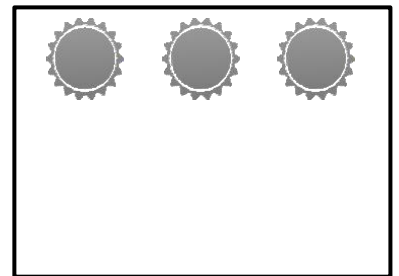

7

DESENHE A QUANTIDADE QUE SE PEDE.

7

VAMOS TREINAR?

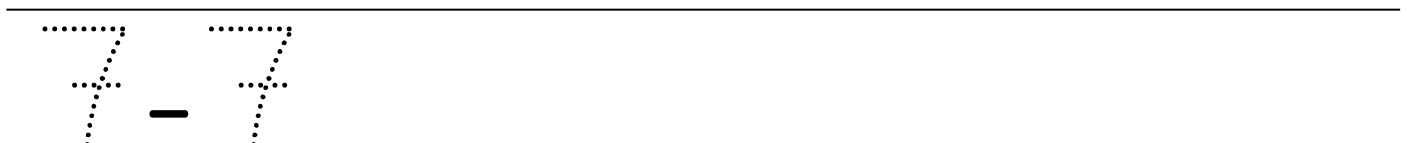

SITUAÇÃO PROBLEMA:

O ÔNIBUS LEVA 6 CRIANÇAS PARA ESCOLA:





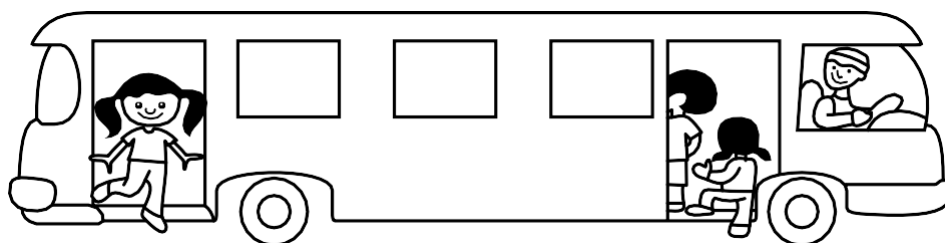



NA PRIMEIRA ESCOLA 1 CRIANÇA DESCEU E 2 SUBIRAM:

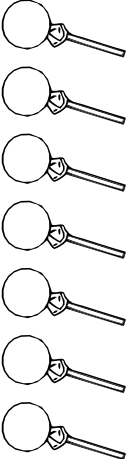

QUANTAS CRIANÇAS ESTAVAM NO ÔNIBUS ANTES DA PARADA?

QUANTAS CRIANÇAS TÊM NO ÔNIBUS AGORA?

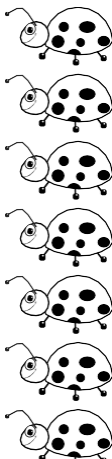
PINTE A QUANTIDADE QUE SE PEDE.

| 5 | 4 | 7 | 3 | 2 | 1 | 6 |
|---|---|---|---|---|---|---|
|  |  |  |  |  |  |  |



MEU NOME É:

HOJE É DIA:

| | |
|--|--|
| | |
|--|--|

NÚMERO 8

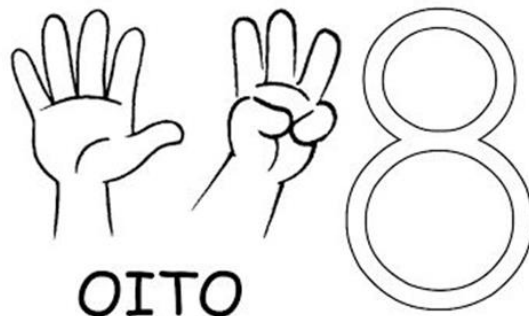

OITO

COMPLETE OS CONJUNTOS DE ACORDO COM O NUMERAL.

SOMOS 8 SAPINHOS. VOCÊ DEVE NOS DISTRIBUIR NAS PLANTAS PARA QUE CADA UMA FIQUE COM O MESMO NÚMERO DE SAPOS.

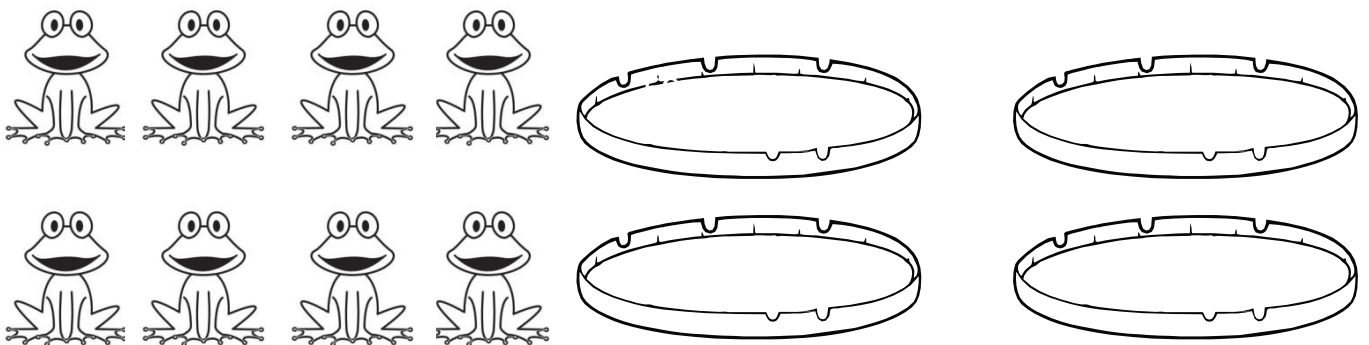

CUBRA OS PONTILHADOS E CONTINUE AO LADO:



CONTE AS DIFERENTES FIGURAS E ESCREVA A QUANTIDADE DE CADA UMA NOS QUADRADOS ABAIXO.

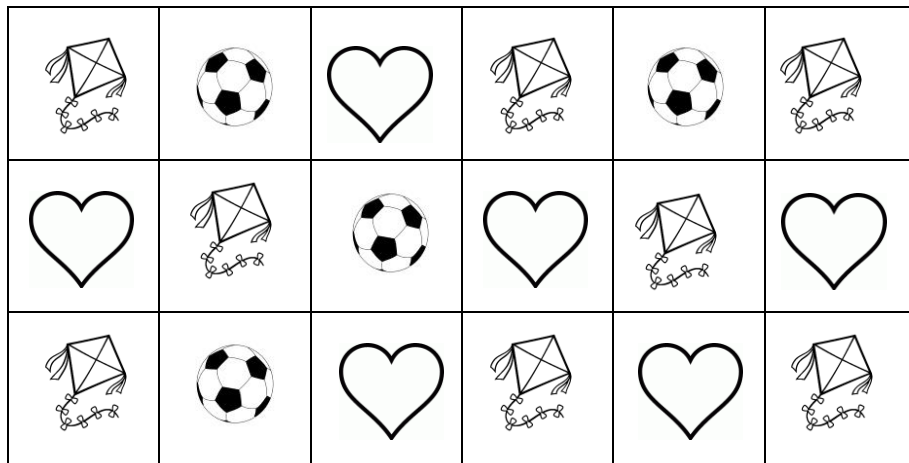





PINTE OS NÚMEROS CORRESPONDENTES AOS DEDINHOS.

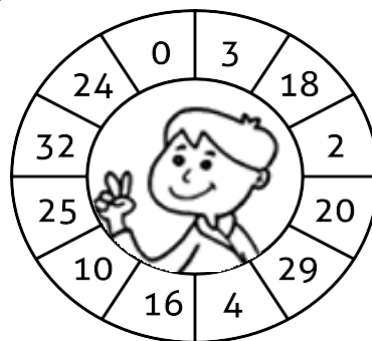
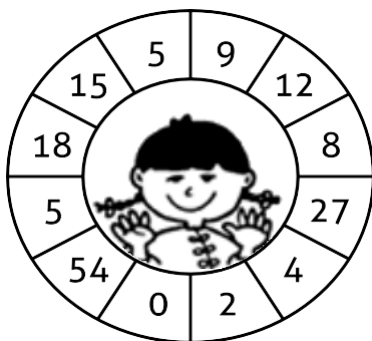
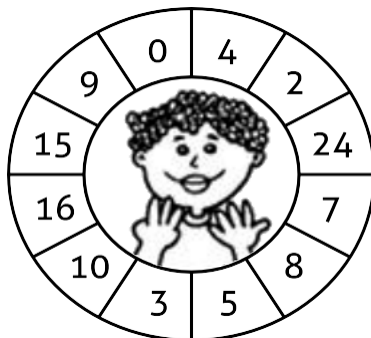
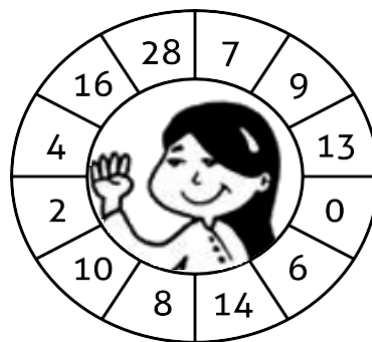
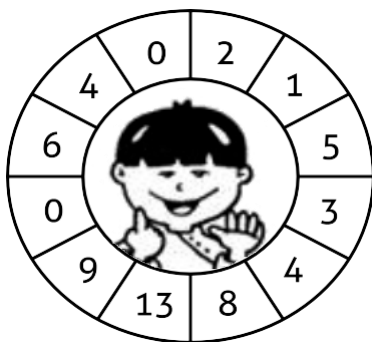

MEU NOME É:

HOJE É DIA:

| | |
|--|--|
| | |
|--|--|

NÚMERO 9

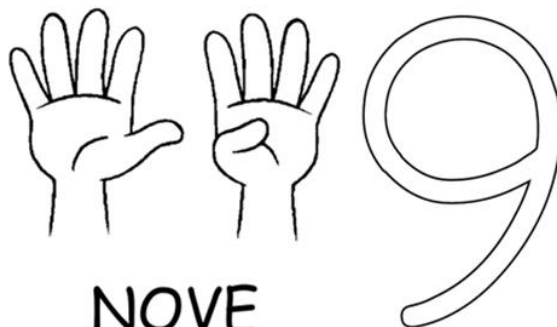

NOVE

CIRCULE OS CONJUNTOS COM 9 OBJETOS.

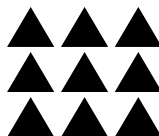
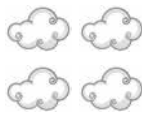

PINTE A QUANTIDADE DE QUADRADINHOS DE ACORDO COM O NÚMERO QUE SEU PROFESSOR DITAR:

| | | | | | | | | | | | |
|--|--|--|--|--|--|--|--|--|--|--|--|
| | <table border="1"> <tr> <td style="width: 10%; height: 30px;"></td> <td style="width: 10%; height: 30px;"></td> <td style="width: 10%; height: 30px;"></td> <td style="width: 10%; height: 30px;"></td> <td style="width: 10%; height: 30px;"></td> <td style="width: 10%; height: 30px;"></td> <td style="width: 10%; height: 30px;"></td> <td style="width: 10%; height: 30px;"></td> <td style="width: 10%; height: 30px;"></td> <td style="width: 10%; height: 30px;"></td> </tr> </table> | | | | | | | | | | |
| | | | | | | | | | | | |
| | <table border="1"> <tr> <td style="width: 10%; height: 30px;"></td> <td style="width: 10%; height: 30px;"></td> <td style="width: 10%; height: 30px;"></td> <td style="width: 10%; height: 30px;"></td> <td style="width: 10%; height: 30px;"></td> <td style="width: 10%; height: 30px;"></td> <td style="width: 10%; height: 30px;"></td> <td style="width: 10%; height: 30px;"></td> <td style="width: 10%; height: 30px;"></td> <td style="width: 10%; height: 30px;"></td> </tr> </table> | | | | | | | | | | |
| | | | | | | | | | | | |
| | <table border="1"> <tr> <td style="width: 10%; height: 30px;"></td> <td style="width: 10%; height: 30px;"></td> <td style="width: 10%; height: 30px;"></td> <td style="width: 10%; height: 30px;"></td> <td style="width: 10%; height: 30px;"></td> <td style="width: 10%; height: 30px;"></td> <td style="width: 10%; height: 30px;"></td> <td style="width: 10%; height: 30px;"></td> <td style="width: 10%; height: 30px;"></td> <td style="width: 10%; height: 30px;"></td> </tr> </table> | | | | | | | | | | |
| | | | | | | | | | | | |

VAMOS TREINAR?



CIRCULE O NUMERAL CORRESPONDENTE AOS ELEMENTOS DE CADA CONJUNTO:



| | | |
|---|---|---|
| 2 | 1 | 4 |
|---|---|---|



| | | |
|---|---|---|
| 3 | 5 | 1 |
|---|---|---|



| | | |
|---|---|---|
| 6 | 9 | 8 |
|---|---|---|

SOME OS OBJETOS E REGISTRE O RESULTADO.

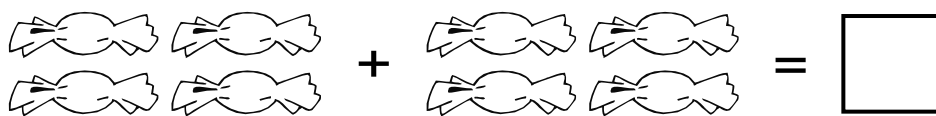
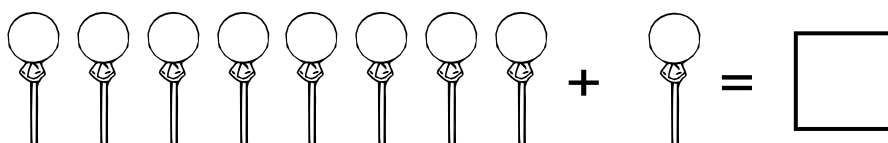

MEU NOME É:

HOJE É DIA:

| | |
|--|--|
| | |
|--|--|

NÚMERO **10**



CONTORNE OS CONJUNTOS COM 10 ELEMENTOS:

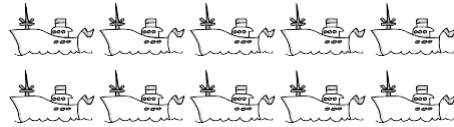
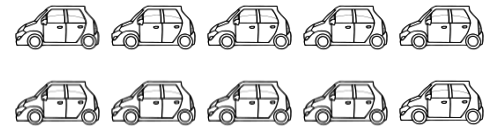

RESOLVA: CADA VAGÃO POSSUI 2 RODAS. QUANTAS RODAS POSSUEM AO TODO?







CUBRA OS PONTILHADOS E CONTINUE AO LADO:

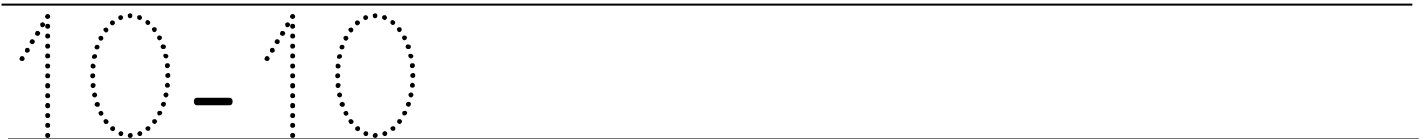

DEZENA E UNIDADE

CONTE QUANTAS FORMIGUINHAS ESTÃO INDO PARA O FORMIGUEIRO:

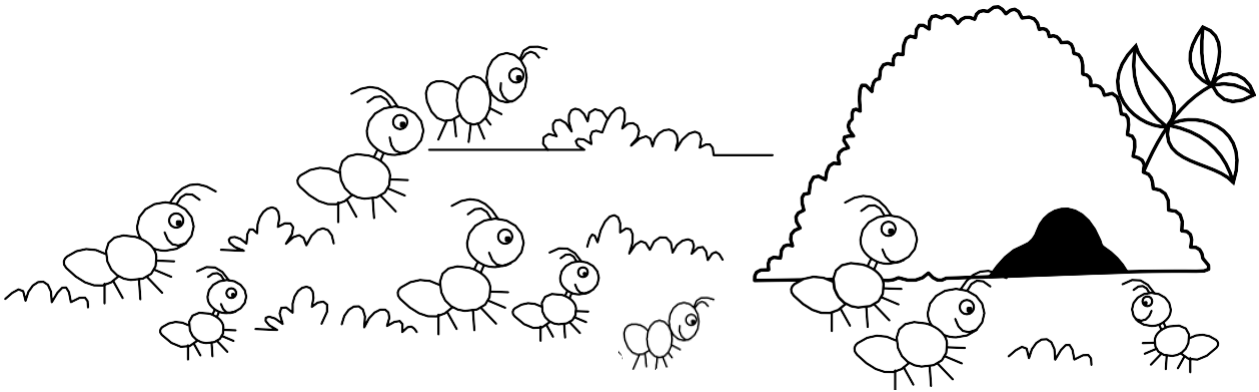

SÃO ___ FORMIGUINHAS A CAMINHO DO FORMIGUEIRO.

CADA FORMIGUINHA REPRESENTA 1 (UMA) **UNIDADE**. 10 UNIDADES FORMAM UMA **DEZENA**.

PINTE UMA DEZENA:

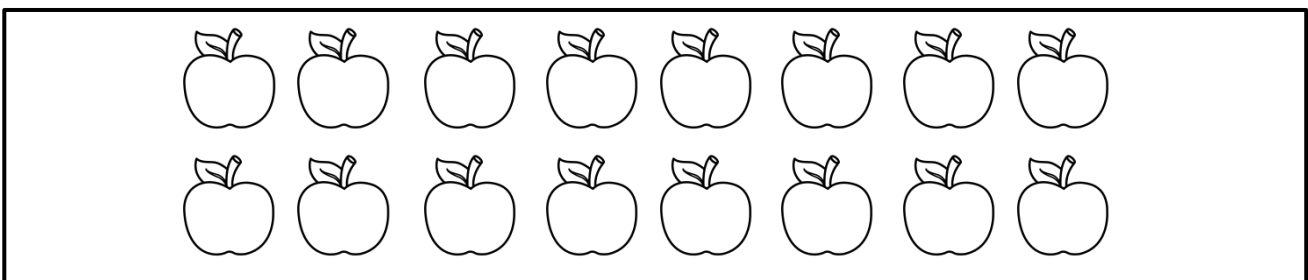
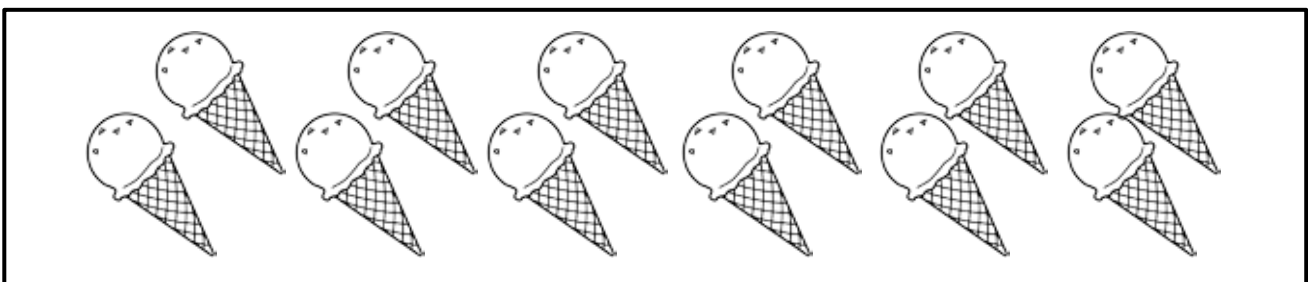
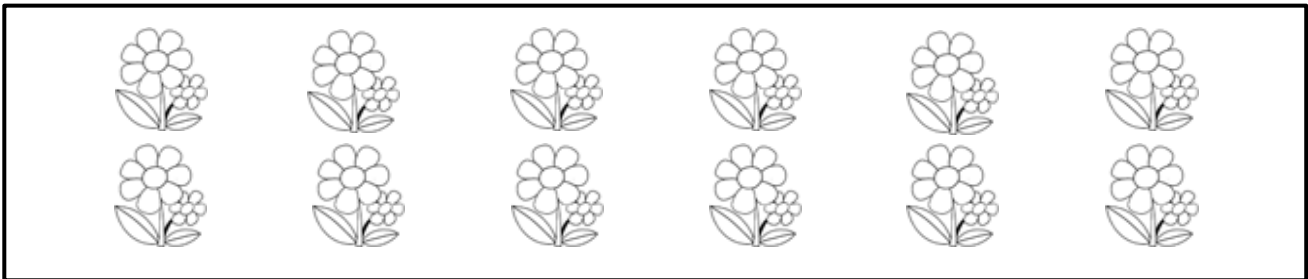

PINTE ONDE TEM AS BOLINHAS E DESCUBRA O QUE APARECE.

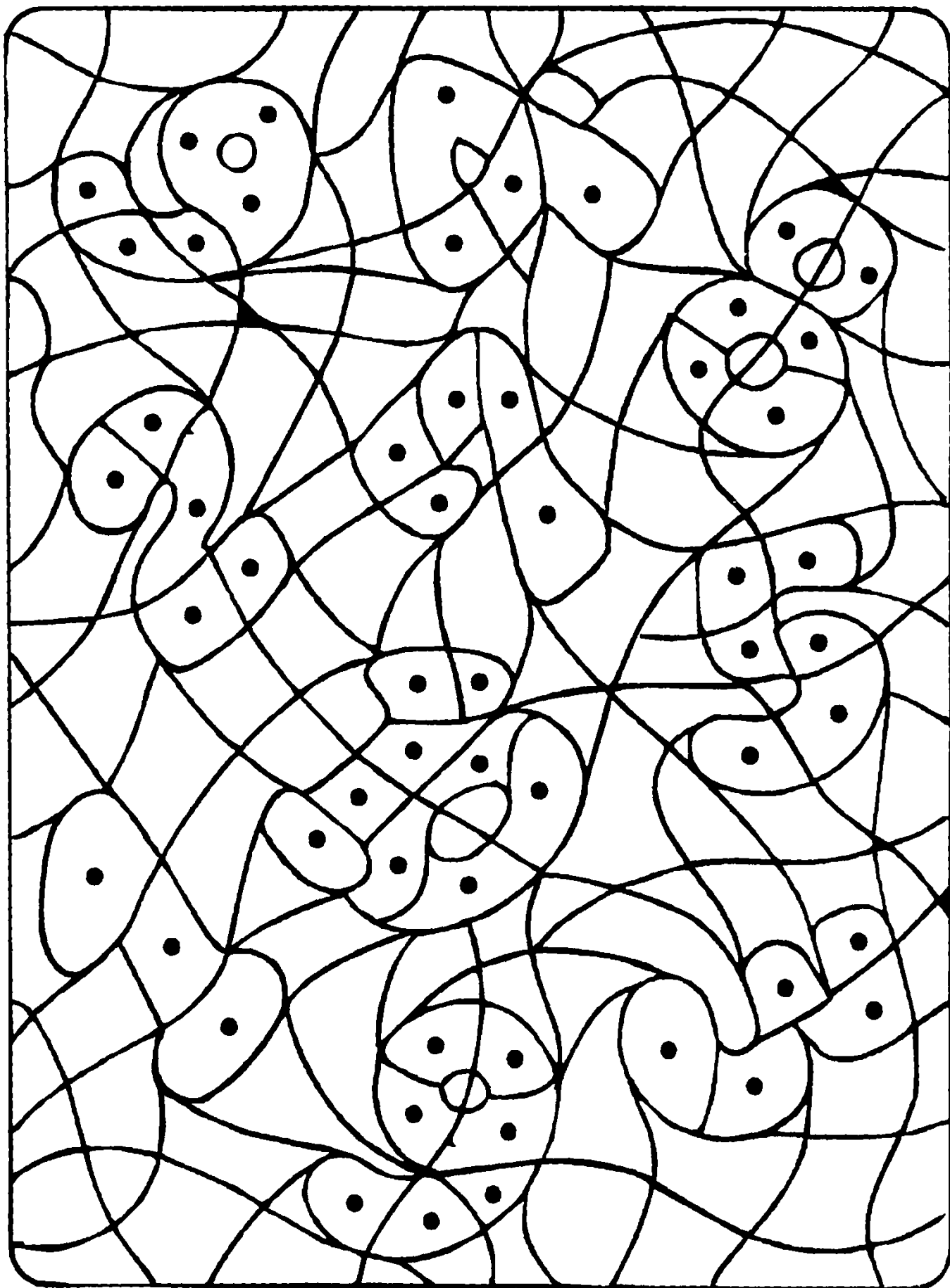

LIGUE OS NÚMEROS NA SEQUÊNCIA E DESCUBRA O DESENHO

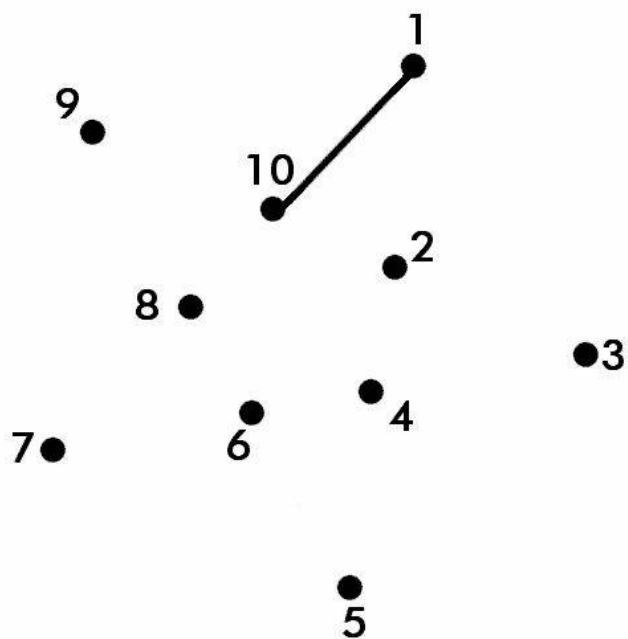

CIRCULE OS 5 ERROS DA IMAGEM

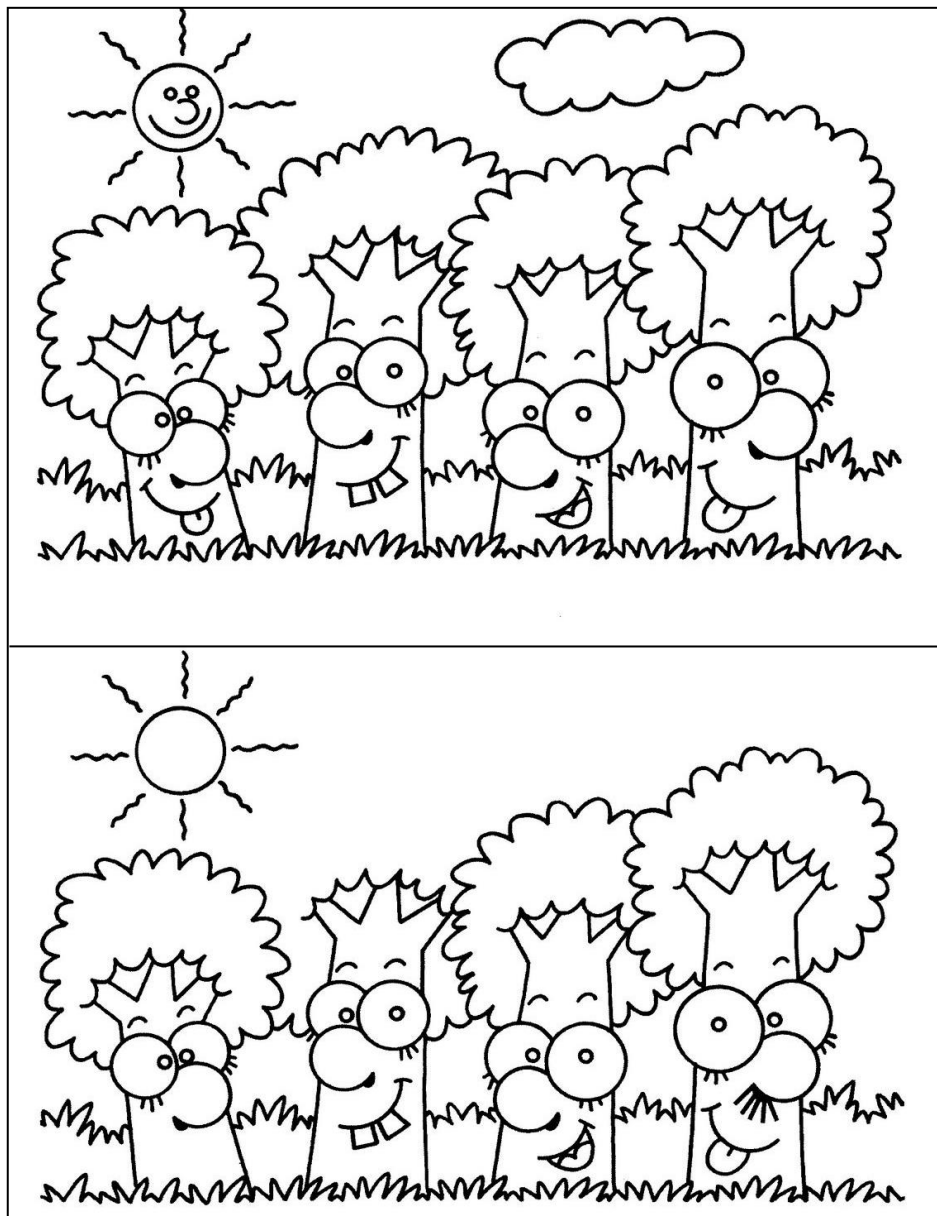

COMPLETE AS SEQUÊNCIAS NUMÉRICAS.



1

 5 7
 9 

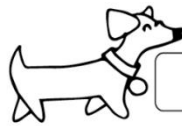

2

4 6 8
 10 



1

 10 

OBSERVE A SEQUÊNCIA E COMPLETE LIGANDO AS FIGURAS FALTANTES



INTERAGINDO COM LIBRAS

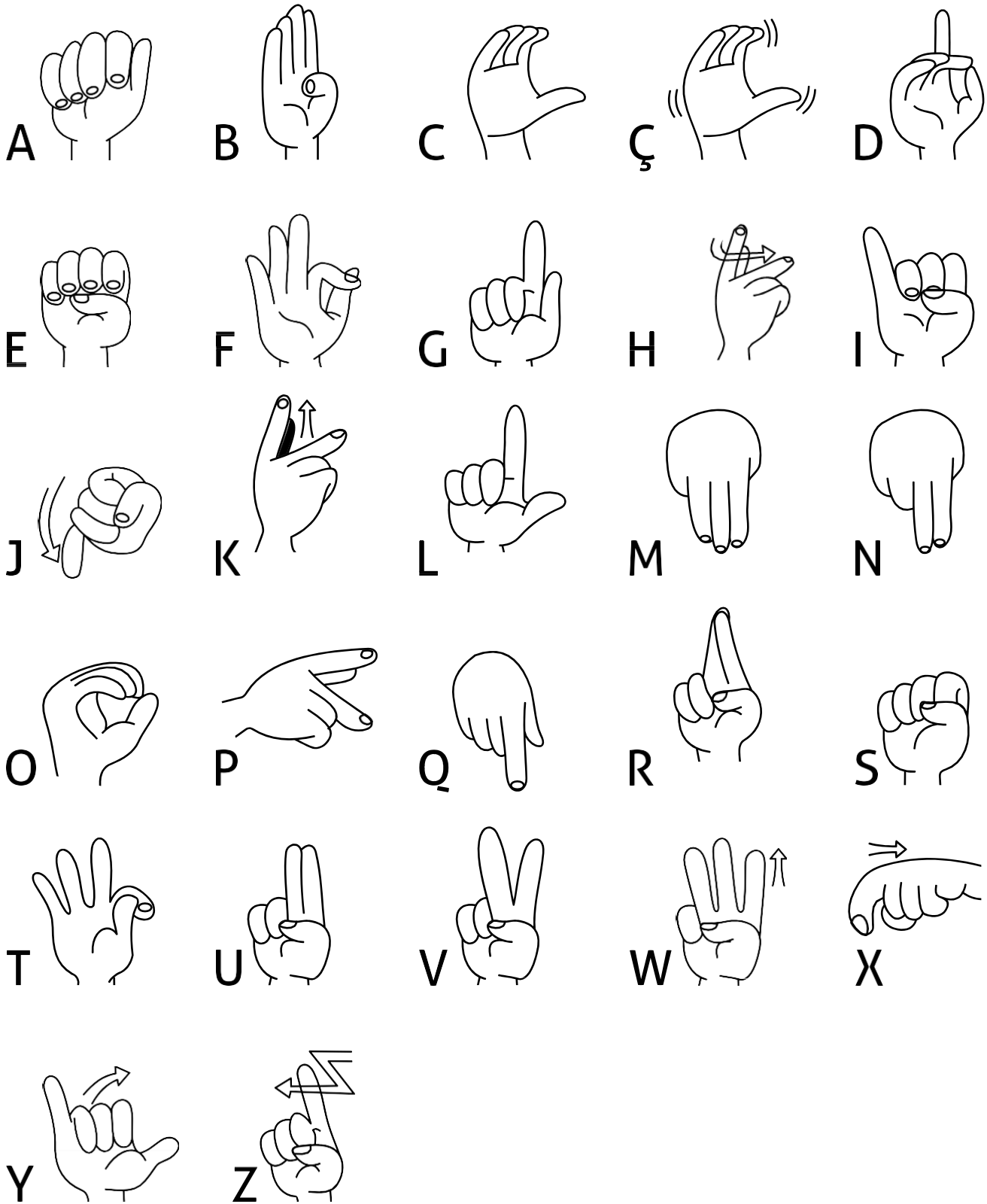

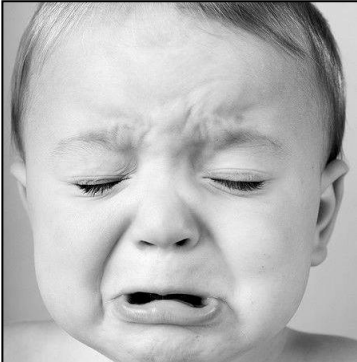
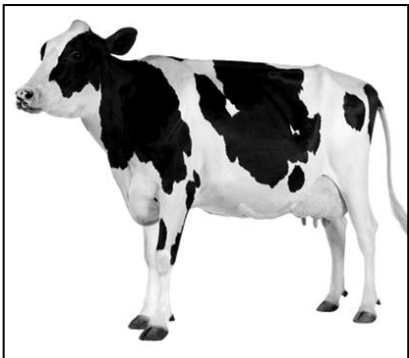
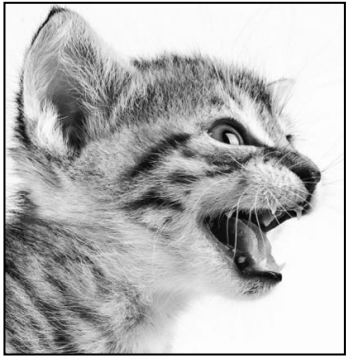
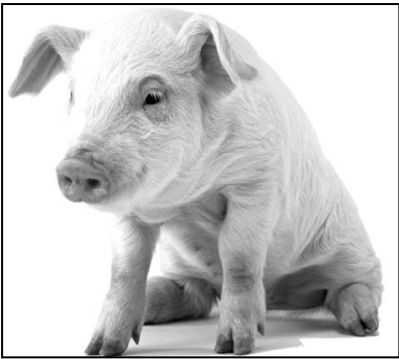

ANEXO PÁGINA 20

PARA FICAR UMA LINDA BORBOLETA, PEÇA PARA AS CRIANÇAS PINTAREM. SE TIVER OUTROS PRODUTOS COMO GLITTER, LANTEJOULAS PODEM COLAR NELA. AGORA, FAÇA UM CORTE NA LINHA AZUL DE CADA OSSINHO, CONFORME O DESENHO ABAIXO. DEPOIS É SÓ UNIR OS CORTES UM NO OUTRO. DE MANEIRA QUE CAIBA O DEDINHO DA CRIANÇA

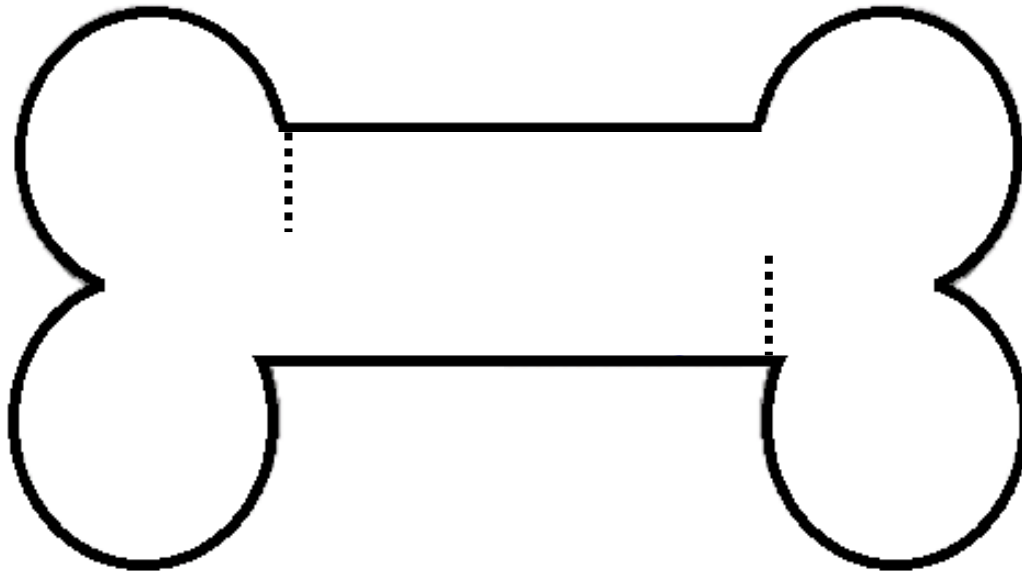

ANEXO PÁGINA 26

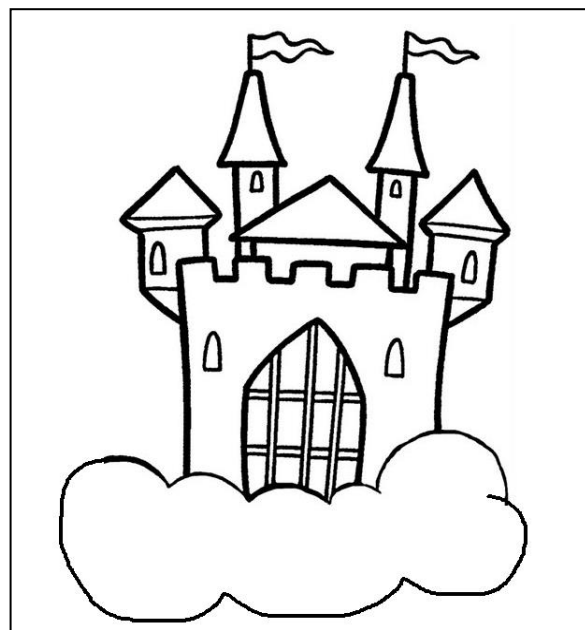

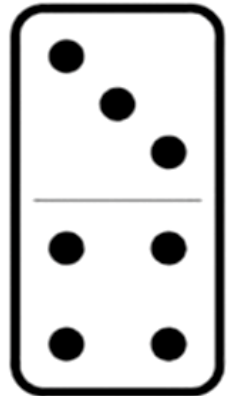
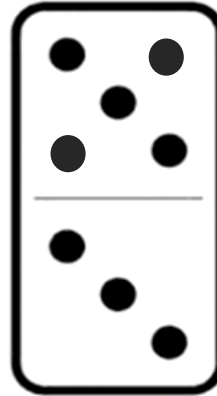
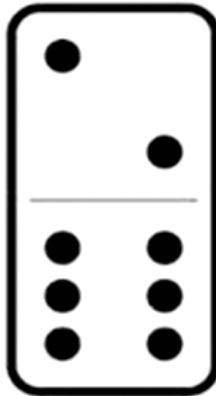
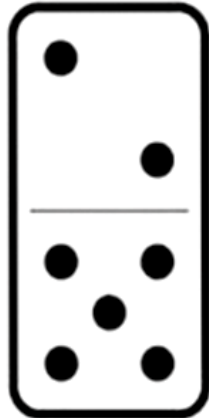
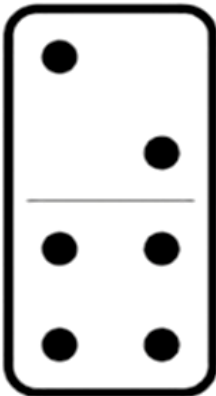
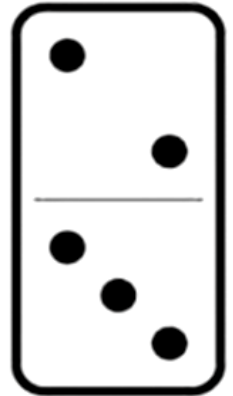
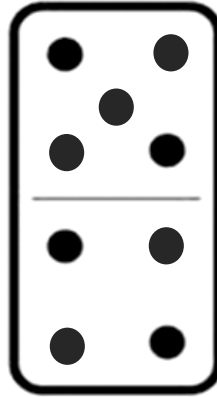
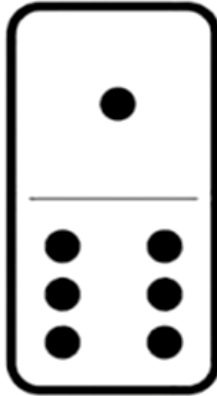
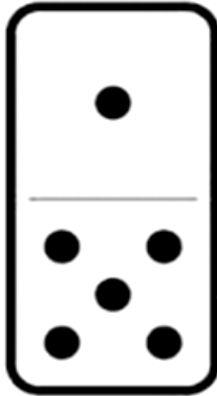
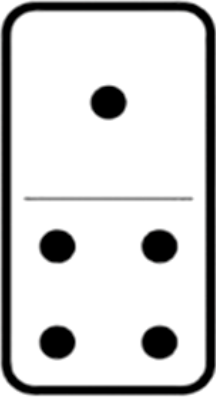
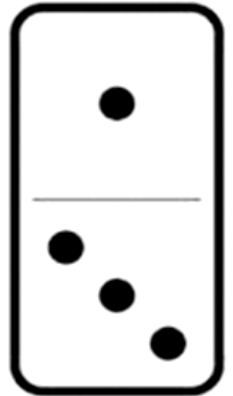
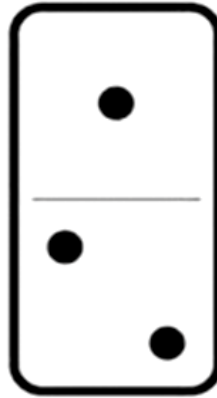
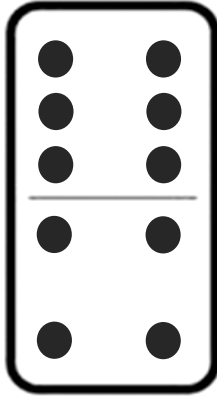
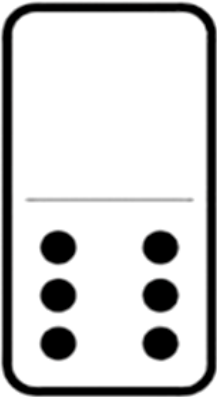
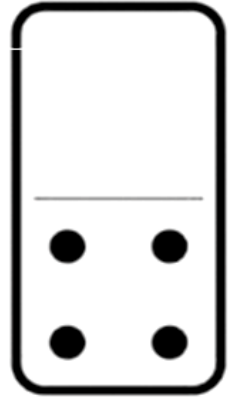
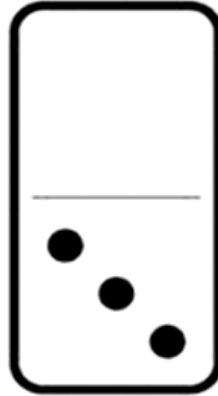
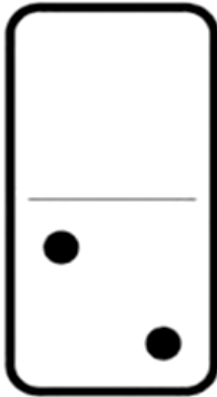
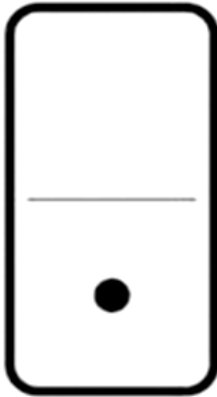
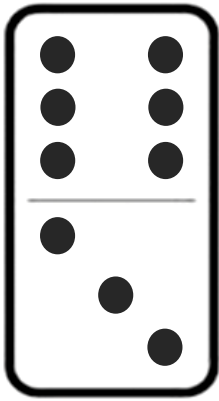

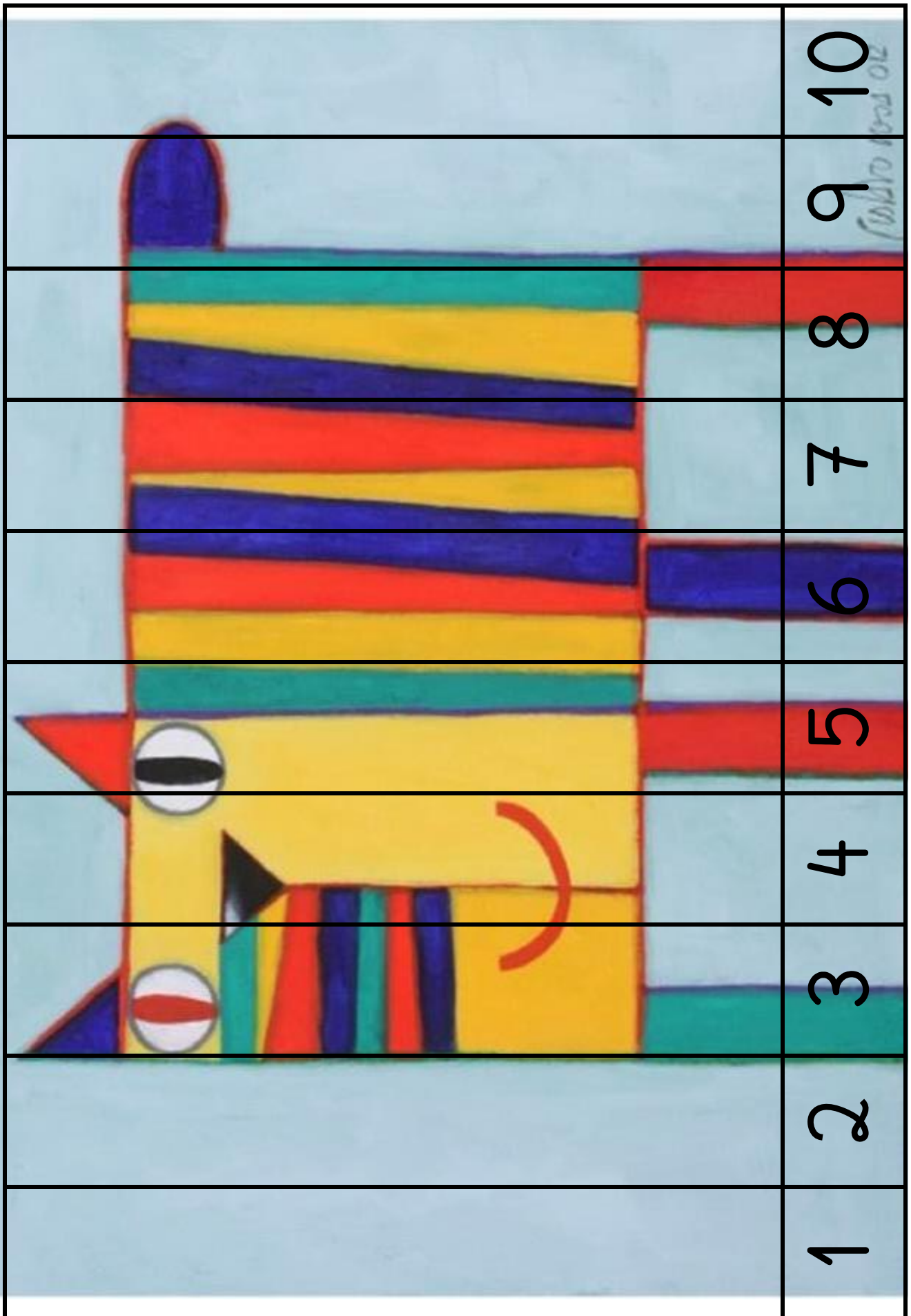

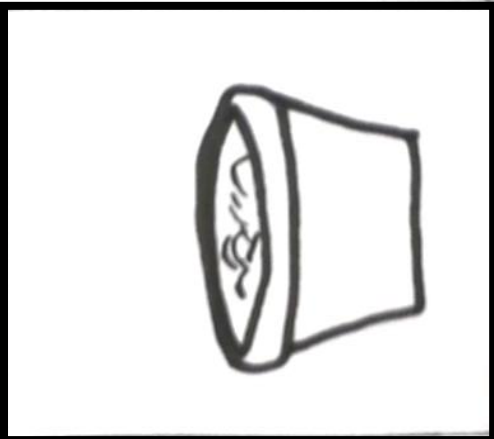
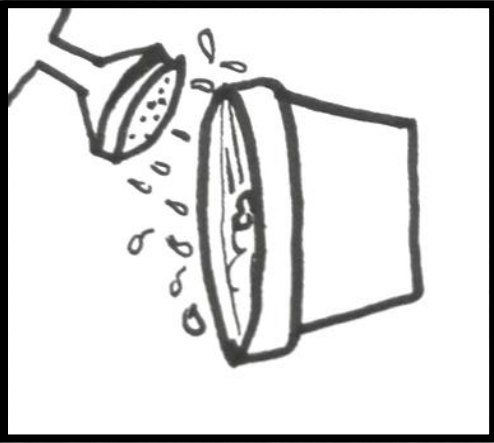
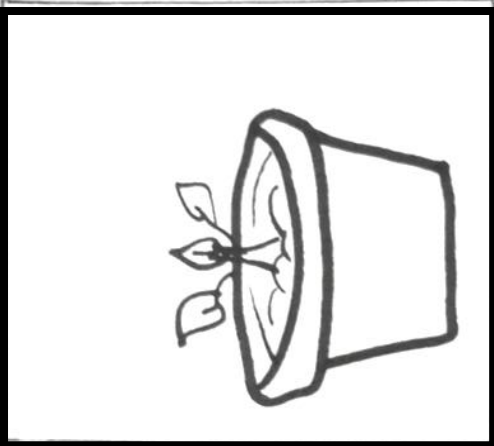
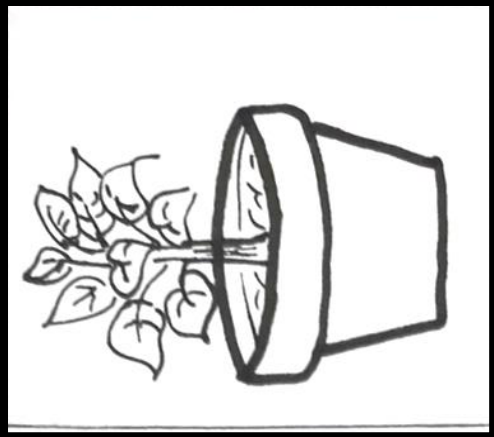

PINTE E RECORTE AS FORMAS GEOMÉTRICAS.
MONTE SUA CASINHA E COLE NO CADERNO DE DESENHO
SEGUNDO O MODELO.

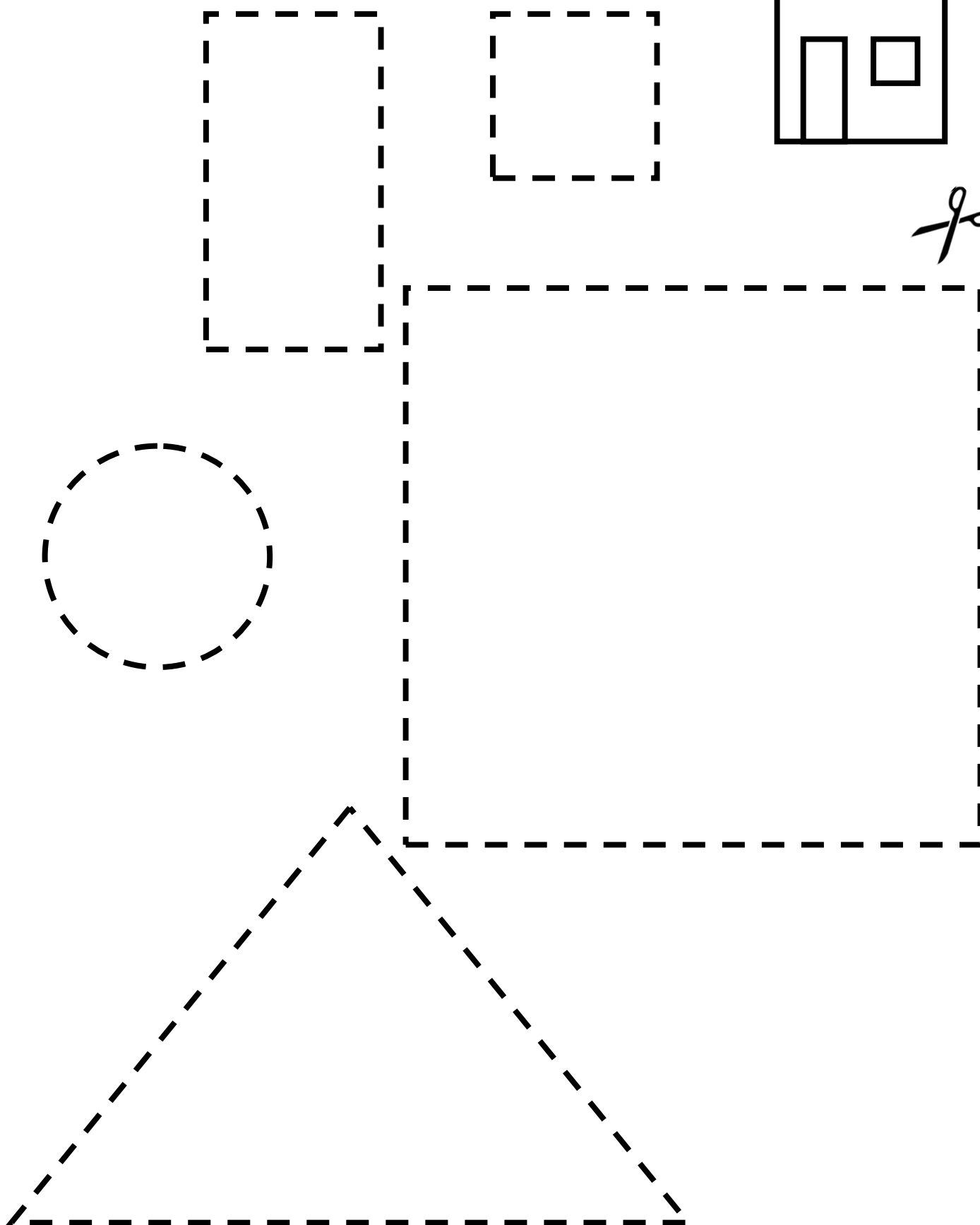
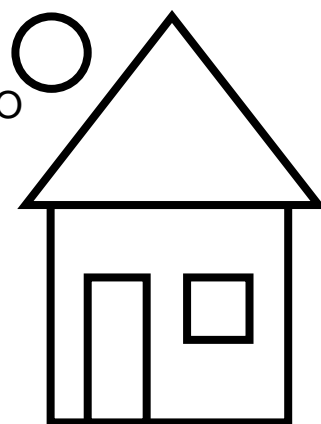

RECORTE AS VOGAIS E COLE PARA COMPLETAR AS PALAVRAS



| | | | | | |
|---|--|---|--|---|--|
| G | | R | | F | |
|---|--|---|--|---|--|



| | | | | |
|---|--|--|---|--|
| P | | | X | |
|---|--|--|---|--|



| | | | | | |
|---|--|---|--|---|--|
| C | | R | | J | |
|---|--|---|--|---|--|

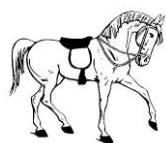

| | | | | | |
|---|--|---|--|---|--|
| C | | V | | L | |
|---|--|---|--|---|--|



A

A

A

A

A

E

E

I

I

O

O









U

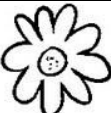
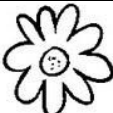
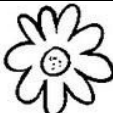
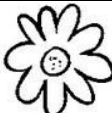

05 DE JUNHO – DIA DO MEIO AMBIENTE

MONTE A ÁRVORE COLOCANDO CADA PARTE EM SEU LUGAR. DEPOIS COLE EM SEU CADERNO DE DESENHO.



| | | | | | | |
|--------|---|---|---|--|---|---|
| FLORES |  |  |  |  |  |  |
| FRUTOS |  |  |  |  |  |  |

TANGRAM

TANGRAM É UM QUEBRA-CABEÇA CHINÊS FORMADO POR 7 PEÇAS – 5 TRIÂNGULOS, 1 QUADRADO E 1 PARALELOGRAMO. PINTE, RECORTE AS FORMAS, BRINQUE COM ELAS E DEPOIS E MONTE ALGUMAS DAS FIGURAS ABAIXO NO SEU CADERNO DE DESENHO.

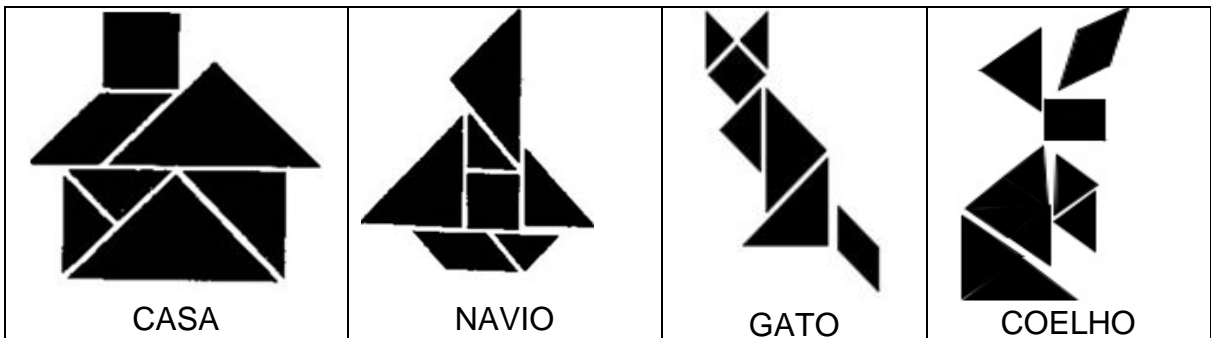
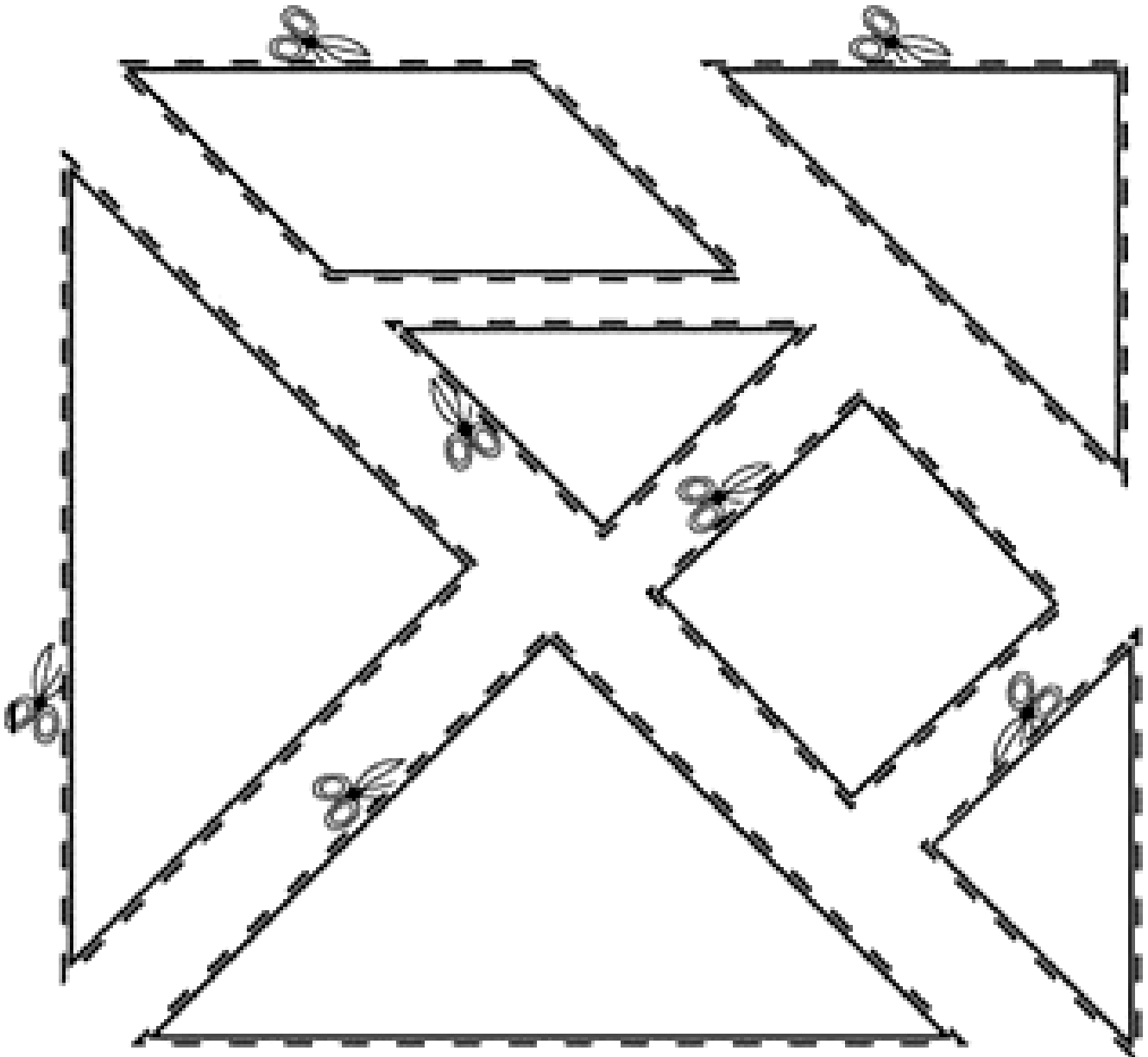

JOGO DA MEMÓRIA
RECORTE AS PEÇAS DO JOGO E BRINQUE COM SEUS COLEGAS

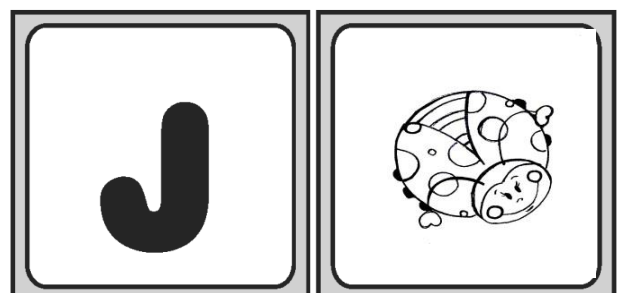
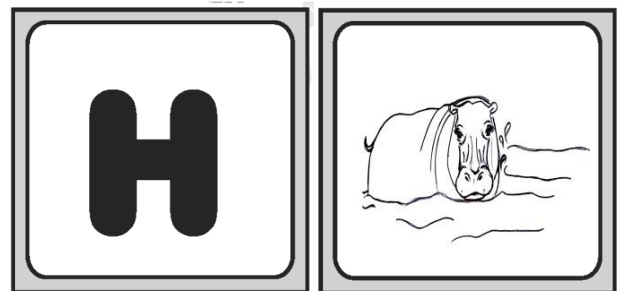
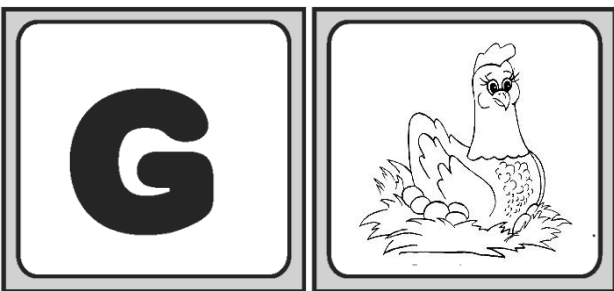
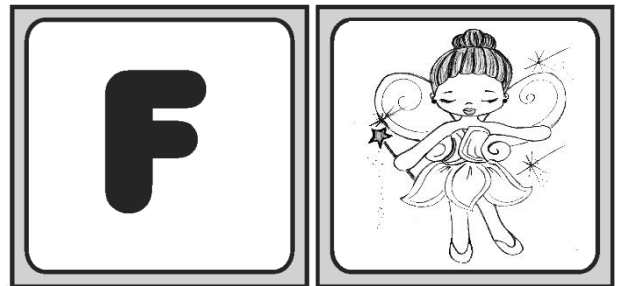
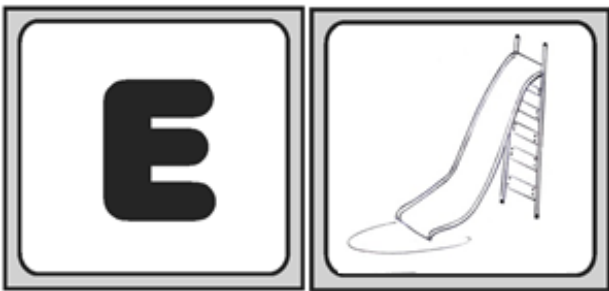
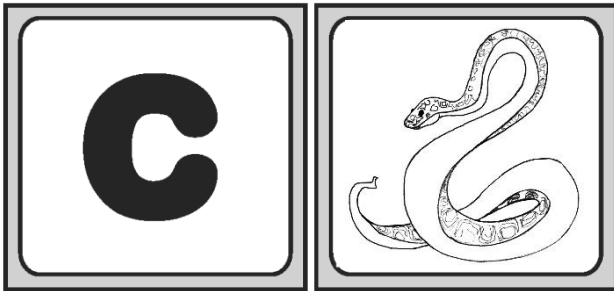
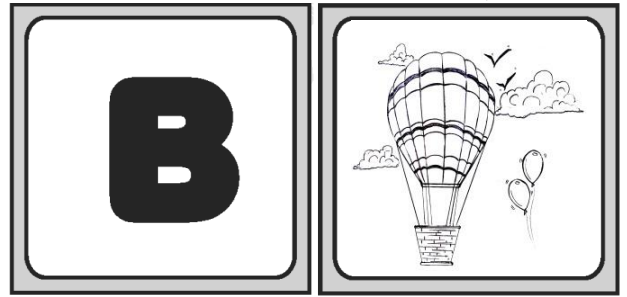

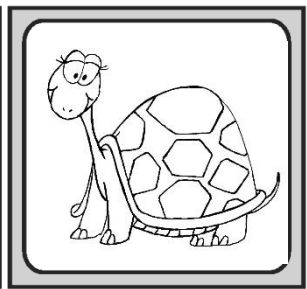
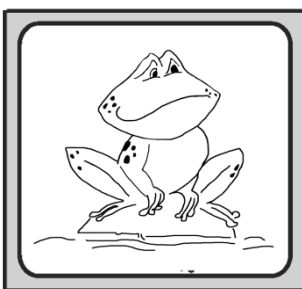
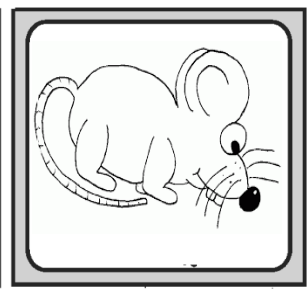
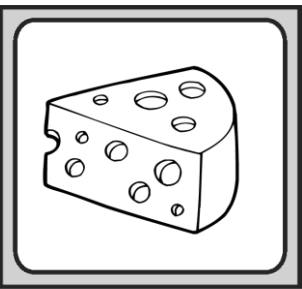
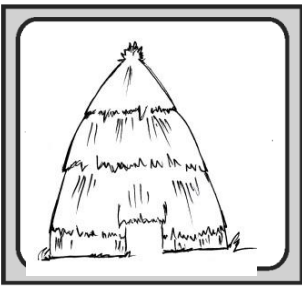
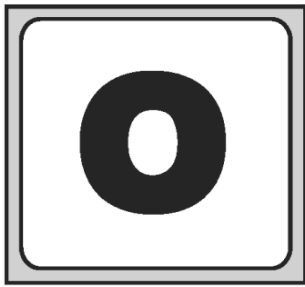
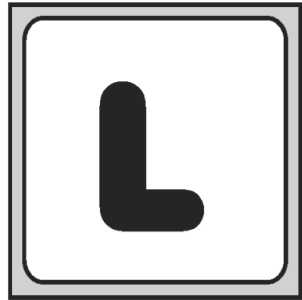

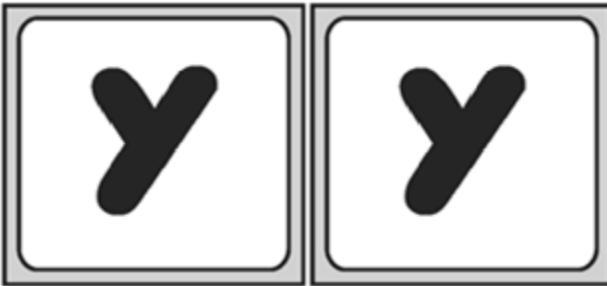
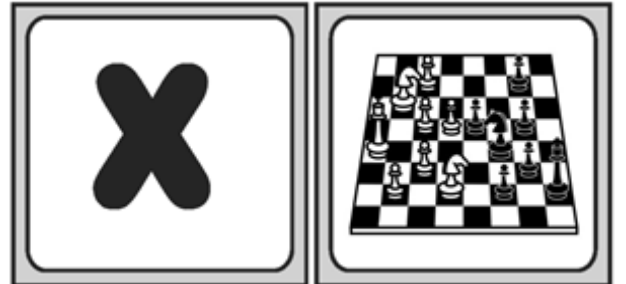
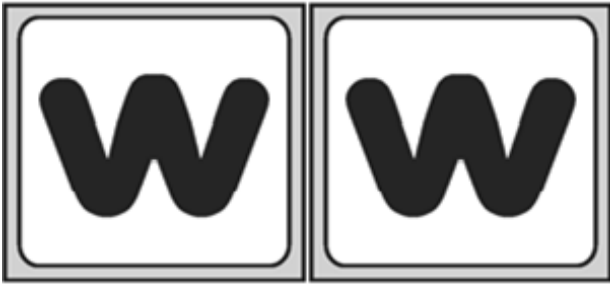
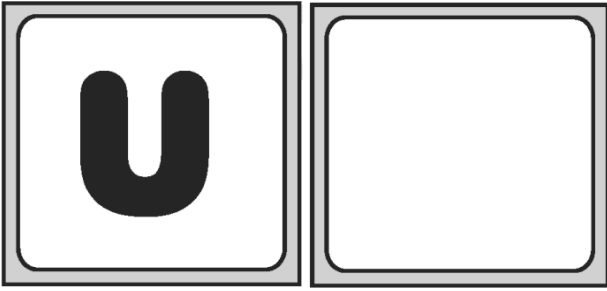



| | | | | | | | | | | |
|---|---|---|---|---|---|---|---|---|---|---|
| A | A | A | A | M | M | M | N | N | N | N |
| B | B | B | C | Q | Q | Q | P | P | P | P |
| D | D | D | E | O | O | O | O | O | R | R |
| E | E | F | F | R | R | R | S | S | S | S |
| G | G | H | H | T | T | T | U | U | U | U |
| I | I | J | J | V | V | V | V | V | X | X |
| K | K | L | L | W | W | W | Y | Y | Z | Z |

